

**CITY OF OWOSSO  
REGULAR MEETING OF THE CITY COUNCIL  
MONDAY, NOVEMBER 4, 2024  
7:30 P.M.**

**Meeting to be held at the  
Owosso Armory Community Room  
215 N. Water Street**

**AGENDA**

**OPENING PRAYER:**

**PLEDGE OF ALLEGIANCE:**

**ROLL CALL:**

**APPROVAL OF THE AGENDA:**

**APPROVAL OF THE MINUTES OF REGULAR MEETING OF OCTOBER 21, 2024:**

**ADDRESSING THE CITY COUNCIL**

1. Your comments shall be made during times set aside for that purpose.
2. Stand or raise a hand to indicate that you wish to speak.
3. When recognized, give your name and address and direct your comments and/or questions to any City official in attendance.
4. Each person wishing to address the City Council and/or attending officials shall be afforded one opportunity of up to four (4) minutes duration during the first occasion for citizen comments and questions. Each person shall also be afforded one opportunity of up to three (3) minutes duration during the last occasion provided for citizen comments and questions and one opportunity of up to three (3) minutes duration during each public hearing. Comments made during public hearings shall be relevant to the subject for which the public hearings are held.
5. In addition to the opportunities described above, a citizen may respond to questions posed to him or her by the Mayor or members of the Council, provided members have been granted the floor to pose such questions.

**PROCLAMATIONS / SPECIAL PRESENTATIONS**

None.

**PUBLIC HEARINGS**

None.

**CITIZEN COMMENTS AND QUESTIONS**

**CONSENT AGENDA**

1. Special Assessment District No. 2025-01. Authorize Resolution No. 4 setting a public hearing for Monday, November 18, 2024 to receive citizen comment regarding Special Assessment District No. 2025-01 for Howell Street, from the south end to Clinton Street for resurfacing.  
**Master Plan Implementation Goals: 3.4, 3.10.**
2. Special Assessment District No. 2025-02. Authorize Resolution No. 4 setting a public hearing for Monday, November 18, 2024 to receive citizen comment regarding Special Assessment District No. 2025-02 for Lynn Street, from the west end to Howell Street for resurfacing.  
**Master Plan Implementation Goals: 3.4, 3.10.**

3. 2024-2025 DPW Inventory Parts Bid. Approval of the low responsive bid from ETNA Supply Co. (Grand Rapids, MI) for the DPW Inventory Parts Bid in the amount of \$26,905.00.  
**Master Plan Implementation Goals: 3.4.**
4. Grand Avenue Playground Equipment. Approval of the purchase and installation of playground equipment for Grand Avenue Park from GameTime in the amount of \$37,482.67.  
**Master Plan Implementation Goals: 5.2, 5.3.**
5. Traffic Control Order - Glow Owosso Parade, 5K and Tree Lighting. Approve request from Lizzie Fredrick, Owosso Main Street Director, for the street and lot closures for the annual Glow Owosso Parade, 5K, and Tree Lighting on Friday, November 29, 2024 beginning at 12:00 p.m. until 10:00 p.m. and further approve Traffic Control Order No. 1523 formalizing the action.  
**Master Plan Implementation Goals: 4.5, 4.6, 4.16, 5.9, 5.12, 5.17.**
6. WWTP Bulk Polymer Havaflock 560 for 2024-2025. Authorization to enter into a purchase agreement with Haviland Products of Grand Rapids, Michigan for bulk polymer necessary for condition wastewater sludge for an estimated amount of \$31,758.00.  
**Master Plan Implementation Goals: 3.4.**
7. WWTP Secondary Clarifier Change Order #1. Approve Order Order #1 for an increased payment for construction work by RCL Construction Co., Inc. for the WWTP Secondary Clarifier project in the amount of \$76,000.00.  
**Master Plan Implementation Goals: 3.4, 3.7.**
8. Palmer 3A and Juniper 1 Well Houses Project Change Order #5. Approve Change Order #5 for an increased payment for construction work by Sorensen Gross Company for the Palmer 3A and Juniper 1 Well houses project in the amount of \$3,202.00.  
**Master Plan Implementation Goals: 1.5, 3.4.**
9. Fee Schedule. Annual review and approval of the 2024 Fee Schedule.  
**Master Plan Implementation Goals: A.7.**
10. Check Register – October 2024. Affirm check disbursements totaling \$3,086,772.46 for October 2024.
11. Warrant No. 648. Authorize Warrant No. 648 as follows:

<b>Vendor</b>	<b>Description</b>	<b>Fund</b>	<b>Amount</b>
Gould Law PC	Services Rendered from September 10, 2024 – October 14, 2024	Multiple	\$13,218.40

**ITEMS OF BUSINESS**

1. Donation Agreement – 1921 American LeFrance Firetruck. Consider the donation of the 1921 American LaFrance Fire Engine to the Shiawassee Firefighters Memorial.

**COMMUNICATIONS**

1. Brad A. Barrett, Finance Director. Revenue & Expenditure Report – September 2024.
2. Planning Commission. Allen Martin Letter of Resignation.
3. Owosso Historical Commission. Minutes of October 15, 2024.
4. Parks & Recreation Commission. Minutes of October 23, 2024.
5. Planning Commission. Minutes of October 28, 2024.

**CITIZEN COMMENTS AND QUESTIONS**

**NEXT MEETING**

Monday, November 18, 2024 – Regular Meeting

**BOARDS AND COMMISSIONS OPENINGS**

Building Board of Appeals – Alternate - term expires June 30, 2026  
Building Board of Appeals – Alternate - term expires June 30, 2025  
Downtown Historic District Commission – term expires June 30, 2027  
Planning Commission – term expires June 30, 2026  
Planning Commission - term expires June 30, 2027  
Zoning Board of Appeals – Alternate – term expires June 30, 2027  
Zoning Board of Appeals – Alternate – term expires June 30, 2025

**ADJOURNMENT**

The City of Owosso will provide necessary reasonable auxiliary aids and services, such as signers for the hearing impaired and audio recordings of printed materials being considered at the meeting, to individuals with disabilities at the meeting/hearing upon seventy-two (72) hours notice to the City of Owosso. Individuals with disabilities requiring auxiliary aids or services should contact the City of Owosso by writing, calling, or emailing the following: Owosso City Clerk's Office, 301 West Main Street, Owosso, MI 48867; Phone: (989) 725-0500; Email: [city.clerk@ci.owosso.mi.us](mailto:city.clerk@ci.owosso.mi.us). The City of Owosso Website address is [www.ci.owosso.mi.us](http://www.ci.owosso.mi.us).

**CITY OF OWOSSO  
REGULAR MEETING OF THE CITY COUNCIL  
MINUTES OF OCTOBER 21, 2024  
7:30 P.M.  
VIRGINIA TEICH CITY COUNCIL CHAMBERS**

**PRESIDING OFFICER:** MAYOR ROBERT J. TEICH, JR.

**OPENING PRAYER:** PASTOR GARY BEAL  
CHURCH OF JUBILEE

**PLEDGE OF ALLEGIANCE:** TRAVIS SCHNEIDER

**PRESENT:** Mayor Robert J. Teich, Jr., Mayor Pro-Tem Susan J. Osika,  
Councilmembers Janae L. Fear, Jerome C. Haber, Daniel A. Law, and  
Nicholas L. Pidek.

**ABSENT:** Councilmember Emily S. Olson.

**APPROVE AGENDA**

Motion by Councilmember Pidek to approve the agenda as presented.

Motion supported by Mayor Pro-Tem Osika and concurred in by unanimous vote.

**APPROVAL OF THE MINUTES OF REGULAR MEETING OF OCTOBER 7, 2024**

Motion by Mayor Pro-Tem Osika to approve the Minutes of the Regular Meeting of October 7, 2024 as presented.

Motion supported by Councilmember Pidek and concurred in by unanimous vote.

**PROCLAMATIONS / SPECIAL PRESENTATIONS**

**Swearing In Ceremony – Firefighter Launa Costello**

Mayor Teich presided over a ceremony to swear in the City's newest firefighter: Launa Costello. Launa's shield was pinned by her father, David Costello. Also on hand to witness were her mother Malinda Costello and boyfriend Anthony Harden.

**Firemen's Memorial Steering Committee Appreciation**

Councilmember Law read aloud the following proclamation of the City of Owosso recognizing the contributions of the members of the Firemen's Memorial Steering Committee for their work in recognizing the County's firefighters that have fallen in the line of duty:

**A RESOLUTION OF APPRECIATION  
FROM THE COUNCIL OF THE CITY OF OWOSSO, MICHIGAN  
TO THE FIREMEN'S MEMORIAL STEERING COMMITTEE**

Whereas, the City of Owosso would like to honor those firefighters that were lost while in the line of duty; and

Whereas, the City of Owosso has sought to create a firemen's memorial using the City's 1921 American LaFrance firetruck; and

Whereas, in July of 2018 the City of Owosso did appoint a steering committee to fulfill these goals; and

Whereas, the Committee has worked tirelessly to raise the funds necessary to plan and construct a permanent display, and this effort is worthy of commendation.

Now, therefore be it resolved, that the City of Owosso extends its deepest thanks, and gratitude for the commitment and hard work of the members of Firemen's Memorial Steering Committee: Travis Schneider, Teresa Schnieder, Sarah Keeley Moorodian, Eric and Teri Mogg, Gordan Settlemyer, Ross Stanley, Mary Long, and Dan Law.

Furthermore, be it resolved, that the City of Owosso recognizes Doug Stanley, Tim Reid and John Reid for their generous contribution of time, expertise, and equipment for the annual Firemen's Memorial BBQ. Even though they aren't members of the Committee, their work and dedication to the success of the event is very much appreciated.

Furthermore, be it resolved, that the City of Owosso also acknowledges and honors the work of Committee members lost over the years: Councilman Burton Fox, Rick Schneider, and Russ Wahl.

Furthermore, be it resolved, that the City of Owosso confers upon you this special commendation to show our appreciation, and our great thanks for your dedication to this cause, and public safety overall. Your service deserves recognition and is truly appreciated by all involved.

Resolved this 21<sup>st</sup> day of October, 2024.

Upon returning to the dais, Councilmember Law suggested that Council consider spinning off the Firemen's Memorial Steering Committee to stand alone as an independent organization because the scope of the mission had changed over the years to include all fallen firefighters in Shiawassee County and they had obtained tax-exempt status from the IRS so they no longer need to rely on the City for said status.

Motion by Councilmember Law to spin off the Firemen's Memorial Steering Committee from a City committee to an independent organization.

Motion supported by Mayor Pro-Tem Osika.

Roll Call Vote.

AYES: Councilmembers Pidek, Haber, Mayor Pro-Tem Osika, Councilmembers Fear, Law, and Mayor Teich.

NAYS: None.

ABSENT: Councilmember Olson.

## **PUBLIC HEARINGS**

### **Proposed Special Assessment District No. 2025-103 - Hazards & Nuisances**

A public hearing was conducted to receive citizen comment regarding proposed Special Assessment District No. 2025-103, Hazards & Nuisances, as it relates to unpaid costs incurred in the altering, repairing, tearing down, abating or removing of hazards and nuisances.

There were no citizen comments made prior to, or during the hearing.

Motion by Councilmember Pidek to approve Special Assessment District Roll No. 2025-103, Hazards & Nuisances, as it relates to unpaid costs incurred in the altering, repairing, tearing down, abating or removing of hazards and nuisances as follows:

**RESOLUTION NO. 175-2024**

**AUTHORIZING THE ROLL FOR  
SPECIAL ASSESSMENT DISTRICT NO. 2025-103, HAZARDS & NUISANCES**

WHEREAS, the Council, after due and legal notice, has met and there being no one to be heard, motion by Councilmember Pidek to adopt Special Assessment Resolution No. 2 for the annual hazards & nuisances roll, as follows:

<b>Parcel #</b>	<b>Address</b>	<b>Srvc Code</b>	<b>Amount</b>
050-010-015-001-00	667 GLENWOOD AVE	WEEDS	\$580.00
050-010-015-005-00	651 GLENWOOD AVE	CLEAN	\$336.06
050-010-015-014-00	615 GLENWOOD AVE	WEEDS	\$270.00
050-010-016-020-00	616 GLENWOOD AVE	WEEDS	\$405.00
050-113-008-031-00	1229 MILWAUKEE ST	TREE	\$455.61
050-114-003-010-00	1116 STATE ST	CLEAN	\$4,219.36
050-114-006-001-00	1122 S CEDAR ST	WEEDS	\$270.00
050-240-003-006-00	621 N SAGINAW ST	WEEDS	\$290.00
050-250-000-008-00	602 N SHIAWASSEE ST	WEEDS	\$140.00
050-340-003-005-00	911 LINGLE AVE	WEEDS	\$135.00
050-390-004-012-00	1260 ADAMS ST	WEEDS	\$1,111.20
050-420-004-005-00	612 BROADWAY AVE	WEEDS	\$135.00
050-420-005-009-00	755 DIVISION ST	WEEDS/CLEAN	\$1,488.50
050-553-000-008-00	1500 MCMILLAN AVE	WEEDS	\$150.00
050-601-000-027-00	807 MICHIGAN AVE	WEEDS	\$135.00
050-602-040-008-00	1404 S CHIPMAN ST	WEEDS	\$135.00
050-651-000-013-00	415 GENESEE ST	CLEAN	\$994.46
050-651-022-007-00	222 CORUNNA AVE	WEEDS	\$680.00
050-652-003-006-00	321 E STEWART ST	CLEAN	\$255.39
050-652-008-004-00	808 DIVISION ST	WEEDS	\$140.00
050-652-010-024-00	917 S PARK ST	WEEDS	\$540.00
050-652-010-025-00	S PARK ST	WEEDS	\$405.00
050-652-010-026-00	S PARK ST	WEEDS	\$405.00
050-660-022-004-00	216 S ELM ST	WEEDS	\$614.56
050-710-001-012-00	915 CORUNNA AVE	WEEDS	\$565.96

and

WHEREAS, the Council deems said Special Assessment Roll- Hazards and Nuisances to be fair, just and equitable and that each of the assessments contained thereon results in the special assessment being in accordance with the unpaid costs incurred in the altering, repairing, tearing down, abating or removing of hazards and nuisances of said properties.

NOW, THEREFORE, BE IT RESOLVED THAT:

1. Said Special Assessment Roll-Hazards and Nuisances as prepared by the City Assessor in the amount of \$14,856.11 is hereby confirmed and shall be known as Special Assessment Roll-Hazards and Nuisances No. 2025-103.
2. Said Special Assessment Roll-Hazards and Nuisances No. 2025-103 shall be placed on file in the office of the City Clerk who shall attach his warrant to a certified copy thereof within ten (10) days commanding the Assessor to spread the various sums shown thereon as directed by the City Council.

Motion supported by Councilmember Law.

Roll Call Vote.

AYES: Councilmembers Fear, Haber, Pidek, Law, Mayor Pro-Tem Osika, and Mayor Teich.

NAYS: None.

ABSENT: Councilmember Olson.

**Ordinance Amendment – Parks & Recreation Commission Ordinance**

**Master Plan Implementation Goals: 3.14**

A public hearing was conducted to receive citizen comment regarding the proposed amendment to Chapter 2, Administration, Article IV, Boards and Commissions, Division 3, Parks and Recreation Commission, Section 2-242. *Members; appointment, terms, voting, officers*, of the Code of Ordinances.

The following person commented regarding the proposed amendment:

Patrice Martin, 615 N. Park Street, said she thought the proposed amendment would present a great opportunity for an area student. She asked if a position description had been developed to provide clear guidance as to the student’s role on the Commission. Mayor Teich and Assistant City Manager Amy K. Fuller explained the student role.

Whereas, the Council, after due and legal notice, has met and having heard all interested persons, motion by Mayor Pro-Tem Osika that the following ordinance be adopted:

**ORDINANCE NO. 847**

**AMEND CHAPTER 2, ADMINISTRATION,  
ARTICLE IV, BOARDS AND COMMISSIONS,  
DIVISION 3, PARKS AND RECREATION COMMISSION**

WHEREAS, the City of Owosso, Shiawassee County, Michigan, has established by ordinance, a Parks and Recreation Commission to provide quality park and recreation opportunities based upon cost, efficiency and community need; and

WHEREAS, the Parks and Recreation Commission is currently made up of 7 voting members; and

WHEREAS, it is the desire of the Parks and Recreation Commission to add a Student Member to the Commission; and

WHEREAS, it is the long-standing practice of the City Council to hold a public hearing to receive citizen comment regarding any and all proposed ordinance amendments.

NOW THEREFORE BE IT RESOLVED THAT THE CITY OF OWOSSO ORDAINS:

SECTION 1. AMENDMENT. That Chapter 2, Administration, Article IV, Boards and Commissions, Division 3, Parks and Recreation Commission, Section 2-242. *Members; appointment, terms, voting, officers*, shall be amended as follows:

Sec. 2-242. - Members; appointment, terms, voting, officers.

- (a) The members of the parks and recreation commission shall consist of seven (7) voting members appointed by the mayor and approved by the council. The mayor or the designee of the mayor, with council approval, shall be an ex-officio member of the commission. The Mayor shall also appoint, with council approval, one (1) student member.
- (b) The seven (7) voting members shall have terms of two (2) years. The first appointment of the seven (7) members shall be staggered so that three (3) members are appointed for a one-year term and four (4) members shall be appointed to two-year terms. Thereafter each appointment of a member shall be for a two-year term unless it is an appointment to fill a vacancy in office that occurs prior to completion of a term. The student member shall serve a term of one (1) year. The ex-officio member of the commission shall serve for an indefinite term at the pleasure of the mayor.
- (c) Each voting member shall be entitled to one (1) vote. The ex-officio and student member shall not have a vote. Any action shall require a majority vote of the members present at a meeting constituting a quorum. A quorum shall consist of at least four (4) voting members.

SECTION 2. EFFECTIVE DATE. This amendment shall become effective November 11, 2024.

SECTION 3. AVAILABILITY. This ordinance may be purchased or inspected in the city clerk's office, Monday through Friday between the hours of 9:00 a.m. and 5:00 p.m.

Motion supported by Councilmember Pidek.

Roll Call Vote.

AYES: Mayor Pro-Tem Osika, Councilmembers Haber, Pidek, Law, Fear, and Mayor Teich.

NAYS: None.

ABSENT: Councilmember Olson.

### **CITIZEN COMMENTS AND QUESTIONS**



Chrell Hoffman, Aiken Road resident, spoke about the problems she's been experiencing due to the burning of brush at the City's Aiken Road Drop Off Site, including ash covering her home and vehicles, the frequency of the burns, and the smoldering that lingers for a number of days after each fire. She said she has approached several people about the issue, but has yet to find resolution.

Tom Manke, 2910 W. M-21, thanked Council for spinning off the Firemen's Memorial Steering Committee. He said they are doing a wonderful job, and he was looking forward to the establishment of a worthy memorial.

Patrice Martin, 615 N. Park Street, spoke about leadership, noting that true leaders serve the people and are not out to burnish their own ego. She celebrated the fact that there are ten candidates running for City Council and encouraged everyone to be open-minded.

Gary Beal, pastor of the Church of Jubilee, said he appreciates each Councilmember and their service to the community. He went on to highlight the service of Mayor Pro-Tem Sue Osika personally thanking her for her dedication to the City and said he has appreciated getting to know the Mayor.

Mayor Teich invited Ms. Hoffman to speak with him about her issue in his office sometime this week, saying he wanted to look into things.

### **CONSENT AGENDA**

None.

### **ITEMS OF BUSINESS**

#### **Parks & Recreation Commission Bylaws Amendment**

Motion by Councilmember Pidek approving the proposed amendments to Article 2, Organization, Section 1, Members, of the bylaws of the City's Parks & Recreation Commission as follows:

#### **RESOLUTION NO. 176-2024**

#### **TO AMEND THE PARKS AND RECREATION COMMISSION BYLAWS**

WHEREAS, the City of Owosso, Shiawassee County, Michigan, has a Parks and Recreation Commission to provide quality park and recreation opportunities based upon cost, efficiency and community need; and

WHEREAS, the Parks and Recreation Commission is currently made up of 7 members; and

WHEREAS, it is the desire of the Parks and Recreation Commission to add a Student Member to the Commission.

NOW THEREFORE BE IT RESOLVED by the City Council of the City of Owosso, Shiawassee County, Michigan that Article 2, Section 1, Members, shall read as follows:

#### **ARTICLE 2: ORGANIZATION**

##### **SECTION 1: MEMBERS**

The members of the Commission shall be appointed by the Mayor and approved by the City Council.

The Commission shall consist of seven (7) voting members and two (2) non-voting members as described below:

- a) Seven (7) Voting Members;
- b) One (1) Student Member:
  - I. The Student Member does not have a vote;
  - II. The Student Member shall be between the ages of 15-18, and be enrolled in any public or private high school within the City;
  - III. Student Member term shall consist of one year starting in September.
  - IV. The Student Member shall be entitled to and abide by all applicable rules of procedure pertaining to any meeting of the Commission;
  - V. The Student Member shall be subject to all applicable rules of conduct pertaining to members of the Commission;
  - VI. The Student Member shall retain membership so long as the Student Member is in regular attendance at a high school during the school year which falls within the one-year term;
  - VII. The Student Member's attendance shall not be counted to qualify the Commission's quorum.
- c) One (1) Ex Officio:
  - I. The Ex Officio does not have a vote;
  - II. The Mayor or designee of the Mayor shall be the Ex Officio member of the Commission with Council approval.

Motion supported by Councilmember Fear.

Roll Call Vote.

AYES: Councilmember Law, Mayor Pro-Tem Osika, Councilmembers Haber, Fear, Pidek, and Mayor Teich.

NAYS: None.

ABSENT: Councilmember Olson.

### **COMMUNICATIONS**

Tanya S. Buckelew, Planning & Building Director. 2024 Liquor License Inspections.  
Tanya S. Buckelew, Planning & Building Director. September 2024 Building Department Report.  
Tanya S. Buckelew, Planning & Building Director. September 2024 Code Violations Report.  
Tanya S. Buckelew, Planning & Building Director. September 2024 Inspections Report.  
Tanya S. Buckelew, Planning & Building Director. September 2024 Certificates Issued Report.  
Kevin D. Lenkart, Public Safety Director. September 2024 Police Report.  
Kevin D. Lenkart, Public Safety Director. September 2024 Fire Report.  
Downtown Development Authority/Main Street. Minutes of October 2, 2024.

### **CITIZEN COMMENTS AND QUESTIONS**

Tom Manke, 2910 W. M-21, spoke out against the Fair Mavens group saying they will destroy the City.

Shelly Ochodnicky, 494 Hintz Road, thanked the community for coming together to fill the 53' trailer that left Owosso two weeks ago to help hurricane victims in North Carolina. She thanked Rex Wheeler and all those that helped to pack the supplies.

Elaine Wagle, 927 N. Parks Street, said the smell of burning bothers her as well, but what really gets her is the heavy smell of pot in places around the City. She said she can't enjoy her yard or open the windows in her house because of the smell of pot.

Mayor Teich noted that the City Manager and the City Clerk will not be present for the next City Council meeting and said he wanted to take the opportunity to thank them for their mentoring and support as he has gone about the job of mayor.

**NEXT MEETING**

Monday, November 04, 2024 – Regular Meeting  
Tuesday, November 12, 2024 – Organizational Meeting

**BOARDS AND COMMISSIONS OPENINGS**

Building Board of Appeals – Alternate - term expires June 30, 2026  
Building Board of Appeals – Alternate - term expires June 30, 2025  
Downtown Historic District Commission – term expires June 30, 2027  
Planning Commission - term expires June 30, 2027  
Zoning Board of Appeals – Alternate – term expires June 30, 2027  
Zoning Board of Appeals – Alternate – term expires June 30, 2025

**ADJOURNMENT**

Motion by Mayor Pro-Tem Osika for adjournment at 8:20 p.m.

Motion supported by Councilmember Law and concurred in by unanimous vote.

\_\_\_\_\_  
Robert J. Teich, Jr., Mayor

\_\_\_\_\_  
Amy K. Kirkland, City Clerk



## MEMORANDUM

---

301 W. MAIN ▪ OWOSSO, MICHIGAN 48867-2958 ▪ WWW.CI.OWOSSO.MI.US

---

DATE: November 4, 2024

TO: Owosso City Council

FROM: Clayton Wehner, Director of Engineering

SUBJECT: Setting Public Hearing for Special Assessment Roll for Howell Street Resurfacing

### RECOMMENDATION:

City staff recommends approval of Resolution No. 4 which sets the second public hearing for the Howell Street Resurfacing Project.

### BACKGROUND:

This public hearing is intended to provide affected residents with the opportunity to comment regarding their individual assessments.

As you will recall, Step Four/Resolution No. 4 takes place after the bids are received. Estimated assessment amounts are adjusted if necessary to reflect the actual cost as dictated by the bids received. A second public hearing is set to allow property owners to comment on their particular assessment. Each property owner is sent a second notice containing the date and time of the public hearing and the amount of the proposed assessment for their property.

Step Five/Resolution No. 5 documents the second public hearing, finalizes the special assessment roll and sets the terms of payment. This public hearing is designed to allow affected citizens the opportunity to argue whether or not the amount of their assessment is fair and equitable in relation to the benefit they receive from the project. If, after hearing citizen comment, the council decides adjustments need to be made to the assessment roll they may do so. Alternately, if it is felt all the assessments are fair and equitable the resolution may be passed as written.

Tonight the council will be considering Resolution No. 4 for the proposed district as a part of the Consent Agenda. Staff recommends authorization of Resolution No. 4 setting a public hearing for Monday, November 18, 2024 to receive citizen comment regarding the proposed special assessment roll for the following public improvement:

**Special Assessment District No. 2025-01  
Howell Street, a Public Street, from the south end to Clinton Street**

for the following work:

STREET RESURFACING: WIDEN, CRUSH, SHAPE AND COMPACT EXISTING ASPHALT AND OVERLAY WITH NEW ASPHALT; GRAVEL SHOULDERS; STORM SEWER REPLACEMENT IN THE LYNN STREET INTERSECTION; ADA SIDEWALK RAMP INSTALLATION IN THE LYNN STREET INTERSECTION

Attachment(s): Howell Street Resolution No. 4  
Howell Street Special Assessment Roll  
Howell Street Engineer's Estimate  
Howell Street Special Assessment Map

**MASTER PLAN IMPLEMENTATION GOALS: 3.4, 3.10**

**RESOLUTION NO.**

**SPECIAL ASSESSMENT RESOLUTION NO. 4  
SETTING A PUBLIC HEARING  
TO RECEIVE COMMENT REGARDING  
SPECIAL ASSESSMENT DISTRICT NO. 2025-01  
HOWELL STREET, A PUBLIC STREET,  
FROM THE SOUTH END TO CLINTON STREET**

WHEREAS, the Assessor has prepared a special assessment roll for the purpose of specially assessing that portion of the cost of the public improvements more particularly hereinafter described to the properties specially benefited by said public improvement, and the same has been presented to the Council by the City Clerk.

NOW, THEREFORE, BE IT RESOLVED THAT:

1. Said special assessment roll is hereby accepted and shall be filed in the office of the City Clerk for public examination.
2. The Council shall meet at the Owosso City Hall, Owosso, Michigan at 7:30 p.m., on Monday, November 18, 2024 for the purpose of hearing all persons interested in said special assessment roll and reviewing the same.
3. The City Clerk is directed to publish the notice of said hearings once in the *Argus Press*, the official newspaper of the City of Owosso, not less than ten (10) days prior to said hearing and shall further cause notice of said hearing to be sent by first class mail to each owner of the property subject to assessment, as indicated by the records in the City Assessor's office as shown on the general tax rolls of the City, at least ten (10) days before the time of said hearing, said notice to be mailed to the addresses shown on said general tax rolls of the City.
4. The notice of said hearing to be published and mailed shall be in substantially the following form:

**NOTICE OF HEARING  
TO REVIEW SPECIAL ASSESSMENT ROLL  
CITY OF OWOSSO, COUNTY OF SHIAWASSEE, MICHIGAN**

TO THE OWNERS OF THE FOLLOWING DESCRIBED PROPERTY:

**Howell Street, a Public Street, from the south end to Clinton Street**

TAKE NOTICE that a Special Assessment roll has been prepared for the purpose of defraying the Special Assessment district's share of the cost of the following described improvements:

**Street Resurfacing**

The said Special Assessment roll is on file for public examination with the City Clerk and any objections to said Special Assessment roll must be filed in writing with the City Clerk prior to the close of the hearing to review said Special Assessment roll.

TAKE FURTHER NOTICE that appearance and protest at this hearing is required in order to appeal the amount of the special assessment to the State Tax Tribunal if an appeal should be desired. A property owner or party in interest, his or her agent, may appear in person at the hearing to protest the special assessment or may file his or her appearance by letter and his or her personal appearance shall not be required. The property owner or any person having an interest in the property subject to the proposed special assessments may file a written appeal of the special assessment with the State Tax Tribunal

within thirty days after confirmation of the special assessment roll if that special assessment was protested at this hearing.

TAKE FURTHER NOTICE that the City Council will meet at the Owosso City Hall, Owosso, Michigan at 7:30 p.m. on Monday, November 18, 2024 for the purpose of reviewing said special assessment roll and for the purpose of considering all objections to said roll submitted in writing.



# City of Owosso

## Proposed Special Assessment No. 2025-01

S. Howell Street  
from Clinton St. to S. end



### Legend

-  Special Assessment Parcels
-  Other City of Owosso Parcels
- 501 Street Address Number

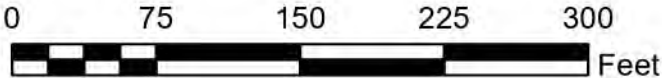

1 August 2024

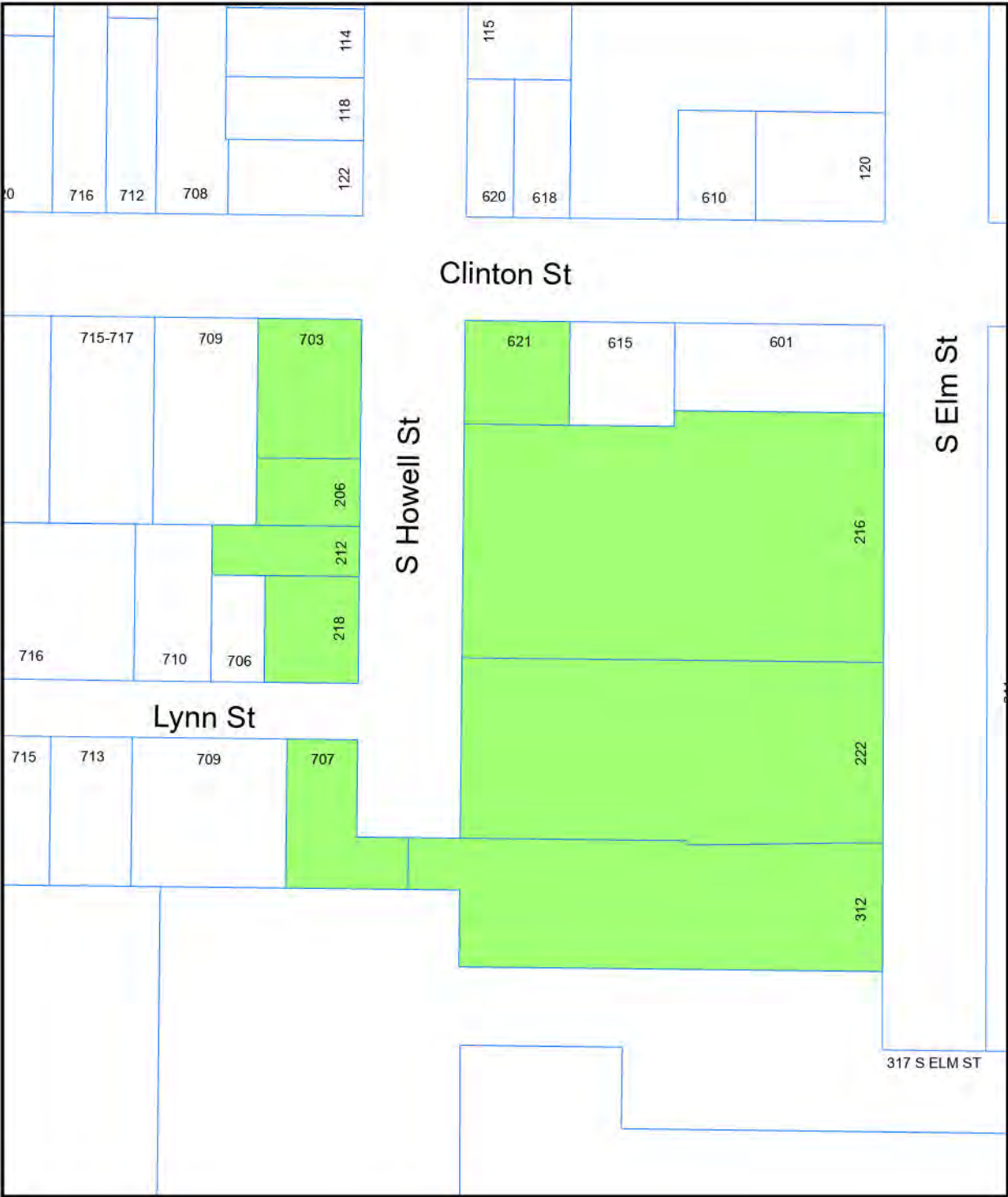



HOWELL STREET FROM SOUTH END TO CLINTON  
LOCAL STREET

SPECIAL ASSESSMENT ROLL 2025-01

RESO 4

WEST SIDE

ADDRESS NO.	STREET	PROPERTY OWNER NAME	ROLL NUMBER	FRONT FOOTAGE	CORNER LOT DISCOUNT	ASSESSABLE FRONT FEET	FRONT FOOT RATE	AMOUNT OF ASSESSMENT	ZONING TYPE	
707	Lynn St	Carol Reno & Rodney Williams	050-660-023-018-00	62	0.6	37.20		\$67.48	\$2,510.26	R1
218	S Howell St	Todd Thompson & Julie Birge	050-660-023-027-00	68	0.6	40.80		\$67.48	\$2,753.18	R1
212	S Howell St	Robert & Cory Lepley	050-660-023-028-00	32	1	32.00		\$67.48	\$2,159.36	R1
206	S Howell St	Sue Ellen Hart	050-660-023-002-00	43	1	43.00		\$67.48	\$2,901.64	R1
703	Clinton St	Eugene Lingo Jr	050-660-023-001-00	89	0.6	53.40		\$67.48	\$3,603.43	R1
				294		206.40			\$13,927.87	

EAST SIDE

ADDRESS NO.	STREET	PROPERTY OWNER NAME	ROLL NUMBER	FRONT FOOTAGE	CORNER LOT DISCOUNT	ASSESSABLE FRONT FEET	FRONT FOOT RATE	AMOUNT OF ASSESSMENT	ZONING TYPE	
222	S Elm St	Willard Holdings LLC	050-660-022-005-00	115	0.6	69.00		\$70.58	\$4,870.02	I1
216	S Elm St	Ramey & Mutee Abdole	050-660-022-004-00	149	0.6	89.40		\$70.58	\$6,309.85	I1
621	Clinton St	Diane Dunn	050-660-022-001-00	66	0.6	39.60		\$67.48	\$2,672.21	R1
				330		198.00			\$13,852.08	

SOUTH SIDE

ADDRESS NO.	STREET	PROPERTY OWNER NAME	ROLL NUMBER	FRONT FOOTAGE	CORNER LOT DISCOUNT	ASSESSABLE FRONT FEET	FRONT FOOT RATE	AMOUNT OF ASSESSMENT	ZONING TYPE	
707	Lynn St	Carol Reno & Rodney Williams	050-660-023-018-00	33	0.6	19.80		\$67.48	\$1,336.10	R1
312	S Elm St	JJEMG Holdings LLC	050-760-000-001-00	33	0.6	19.80		\$70.58	\$1,397.48	PUD
				66		39.60			\$2,733.59	

TOTAL FRONT FEET: 690 TOTAL ASSESSABLE FRONT FEET: 444.00 TOTAL ASSESSMENTS: \$ 30,513.54

HOWELL STREET FROM SOUTH END TO CLINTON STREET ENGINEER'S ESTIMATE

DESCRIPTION	QUANTITY	UNIT	UNIT PRICE	AMOUNT	ELLIGIBLE AMOUNT	CITY COST 60 PERCENT	ASSESSMENT AT 40%	
							RESIDENTIAL	COMMERCIAL
Mobilization, Max ___, (Road and Storm)	0.69	LSUM	\$ 17,195.84	\$ 11,865.13	\$ 11,865.13	\$ 7,119.08	\$ 4,746.05	\$ 4,746.05
Dr Structure, Rem	2	Ea	\$ 363.48	\$ 726.96		\$ -	\$ -	\$ -
Sewer, Rem, Less than 24 inch	36	Ft	\$ 13.08	\$ 470.88		\$ -	\$ -	\$ -
Curb and Gutter, Rem	17	Ft	\$ 9.37	\$ 159.29		\$ -	\$ -	\$ -
Pavt, Rem	31	Syd	\$ 7.95	\$ 246.45	\$ 246.45	\$ 147.87	\$ 98.58	\$ 98.58
Sidewalk, Rem	20	Syd	\$ 5.47	\$ 109.40		\$ -	\$ -	\$ -
Embankment, CIP	50	Cyd	\$ 6.96	\$ 348.00		\$ -	\$ -	\$ -
Excavation, Earth	5	Cyd	\$ 9.08	\$ 45.40		\$ -	\$ -	\$ -
Subgrade Undercutting, Special	69	Syd	\$ 71.89	\$ 4,960.41		\$ -	\$ -	\$ -
Erosion Control, Inlet Protection, Fabric Drop	3	Ea	\$ 93.98	\$ 281.94	\$ 281.94	\$ 169.16	\$ 112.78	\$ 112.78
Subbase, CIP	12	Cyd	\$ 34.94	\$ 419.28		\$ -	\$ -	\$ -
Aggregate Base, 9 inch, Modified	153	Syd	\$ 32.12	\$ 4,914.36		\$ -	\$ -	\$ -
HMA Base Crushing and Shaping, Modified	1069	Syd	\$ 6.10	\$ 6,520.90	\$ 6,520.90	\$ 3,912.54	\$ 2,608.36	\$ 2,608.36
Asphalt Cement Stabilized Base Course, 4 inch	1069	Syd	\$ 9.77	\$ 10,444.13	\$ 10,444.13	\$ 6,266.48	\$ 4,177.65	\$ 4,177.65
Asphalt Cement Binder	1709	Gal	\$ 7.33	\$ 12,526.97	\$ 12,526.97	\$ 7,516.18	\$ 5,010.79	\$ 5,010.79
Material, Surplus and Unsuitable, Rem, LM	40	Cyd	\$ 75.24	\$ 3,009.60		\$ -	\$ -	\$ -
Maintenance Gravel	35	Ton	\$ 39.06	\$ 1,367.10	\$ 1,367.10	\$ 820.26	\$ 546.84	\$ 546.84
Approach, CI I, LM	28	Cyd	\$ 77.06	\$ 2,157.68	\$ 2,157.68	\$ 1,294.61	\$ 863.07	\$ 863.07
Shld, CI I	48	Ton	\$ 44.67	\$ 2,144.16	\$ 2,144.16	\$ 1,286.50	\$ 857.66	\$ 857.66
Trenching, Modified	3	Sta	\$ 656.04	\$ 1,968.12		\$ -	\$ -	\$ -
Sewer, SDR-26, 10 inch, Tr Det B, Modified	129	Ft	\$ 93.22	\$ 12,025.38		\$ -	\$ -	\$ -
Sanitary Service, Conflict	1	Ea	\$ 1,191.72	\$ 1,191.72		\$ -	\$ -	\$ -
Abandoned Gas Main, Conflict	1	Ea	\$ 463.67	\$ 463.67		\$ -	\$ -	\$ -
Dr Structure Cover, Adj, Case 1	1	Ea	\$ 610.49	\$ 610.49	\$ 610.49	\$ 366.29	\$ 244.20	\$ 244.20
Dr Structure, Tap, 10 inch	2	Ea	\$ 531.15	\$ 1,062.30		\$ -	\$ -	\$ -
Dr Structure, Temp Lowering	1	Ea	\$ 538.19	\$ 538.19	\$ 538.19	\$ 322.91	\$ 215.28	\$ 215.28
Dr Structure Cover, EJ 1040 w/ Solid Gasket Sealed Cover	1	Ea	\$ 1,010.80	\$ 1,010.80	\$ 1,010.80	\$ 606.48	\$ 404.32	\$ 404.32
Dr Structure Cover, EJ 1040 w/ Type N Oval Grate	3	Ea	\$ 907.95	\$ 2,723.85	\$ 2,723.85	\$ 1,634.31	\$ 1,089.54	\$ 1,089.54
Dr Structure, 36 inch dia, Modified	2	Ea	\$ 2,044.25	\$ 4,088.50		\$ -	\$ -	\$ -
Dr Structure, 48 inch dia, Modified	1	Ea	\$ 3,740.13	\$ 3,740.13		\$ -	\$ -	\$ -
HMA, 13A @ 5"	286	Ton	\$ 156.04	\$ 44,627.44	\$ 44,627.44	\$ 26,776.46	\$ 14,280.78	\$ 17,850.98
Cement	1	Ton	\$ 305.24	\$ 305.24		\$ -	\$ -	\$ -
Driveway, Nonreinf Conc, 6 inch	35	Syd	\$ 127.63	\$ 4,467.05	\$ 4,467.05	\$ 2,680.23	\$ 1,786.82	\$ -
Detectable Warning Surface, Modified	10	Ft	\$ 91.57	\$ 915.70		\$ -	\$ -	\$ -
Sidewalk, Conc, 6 inch	114	Sft	\$ 11.77	\$ 1,341.78		\$ -	\$ -	\$ -
Curb Ramp, Conc, 4 inch	75	Sft	\$ 20.97	\$ 1,572.75		\$ -	\$ -	\$ -
Curb Ramp, Conc, 7 inch	52	Sft	\$ 23.27	\$ 1,210.04		\$ -	\$ -	\$ -
Water Shutoff, Adj, Temp, Case 1	3	Ea	\$ 341.21	\$ 1,023.63	\$ 1,023.63	\$ 614.18	\$ 409.45	\$ 409.45
Gate Box, Adj, Temp, Case 1	4	Ea	\$ 483.68	\$ 1,934.72	\$ 1,934.72	\$ 1,160.83	\$ 773.89	\$ 773.89
Barricade, Type III, High Intensity, Double Sided, Lighted, Furn & Oper	1	Ea	\$ 79.36	\$ 79.36		\$ -	\$ -	\$ -
Minor Traf Devices, Max \$5,000	0.69	LSUM	\$ 2,079.50	\$ 1,434.86	\$ 1,434.86	\$ 860.91	\$ 573.94	\$ 573.94
Plastic Drum, Fluorescent, Furn & Oper	17	Ea	\$ 23.20	\$ 394.40		\$ -	\$ -	\$ -
Sign, Type B, Temp, Prismatic, Furn & Oper	66	Sft	\$ 6.10	\$ 402.60		\$ -	\$ -	\$ -
Pedestrian Type II Barricade, Temp	3	Ea	\$ 152.62	\$ 457.86		\$ -	\$ -	\$ -

DESCRIPTION	QUANTITY	UNIT	UNIT PRICE	AMOUNT	ELIGIBLE AMOUNT	CITY COST 60 PERCENT	ASSESSMENT	ASSESSMENT
							AT 40%	AT 40%
							RESIDENTIAL	COMMERCIAL
Turf Establishment, Performance	755	Syd	\$ 8.46	\$ 6,387.30		\$ -	\$ -	\$ -
Post, Steel, 3 lb	32	Ft	\$ 10.99	\$ 351.68		\$ -	\$ -	\$ -
Sign, Type III. Erect, Salv	2	Ea	\$ 91.57	\$ 183.14		\$ -	\$ -	\$ -
Sign, Type III, Rem	2	Ea	\$ 61.05	\$ 122.10		\$ -	\$ -	\$ -
SUB TOTALS				\$ 159,352.83	\$ 105,925.48	\$ 63,555.29	\$ 38,800.00	\$ 40,583.37
ENGINEERING AT 15% ASSESSABLE COST				\$ 23,902.93	\$ 15,888.82	\$ 9,533.29	\$ 5,820.00	\$ 6,087.51
ADMINISTRATIVE AT 5% ASSESSABLE COST				\$ 7,967.64	\$ 5,296.27	\$ 3,177.76	\$ 1,940.00	\$ 2,029.17
GRAND TOTALS				\$ 191,223.40	\$ 127,110.58	\$ 76,266.35	\$ 46,560.00	\$ 48,700.05

**HOWELL STREET FROM SOUTH END TO CLINTON  
LOCAL STREET**

**SPECIAL ASSESSMENT ROLL 2025-01**

**RESO 4**

ENGINEER'S ESTIMATE ASSESSABLE AMOUNT \$127,110.58  
 TOTAL FRONT FOOTAGE 690.00

**CALCULATING ASSESSABLE FRONT FOOT RATE AND AMOUNTS:**

PROPERTY TYPE	RESIDENTIAL PROPERTY	COMMERCIAL PROPERTY	TOTAL
TOTAL ASSEMENT PER TYPE	\$127,110.58	\$127,110.58	
CITY SHARE ≥ 60%	\$80,550.58	\$78,410.53	
PROPERTY SHARE @ ≤40%	\$46,560.00	\$48,700.05	
FRONT FOOT RATE: PROP SHARE/TOTAL FRONT FOOTAGE:	\$67.48	\$70.58	
TOTAL ASSESSABLE FRONT FEET PER TYPE:	265.80	178.20	
TOTAL AMOUNT OF ASSESSMENT PER TYPE:	\$17,936.18	\$12,577.36	\$30,513.54

**SUMMARY: SPECIAL ASSESSMENT AMOUNTS PER SIDE OF STREET:**

WEST SIDE	\$	13,927.87
EAST SIDE	\$	13,852.08
SOUTH SIDE	\$	<u>2,733.59</u>
TOTAL SPECIAL ASSESSMENT	\$	30,513.54



## MEMORANDUM

---

301 W. MAIN ▪ OWOSSO, MICHIGAN 48867-2958 ▪ WWW.CI.OWOSSO.MI.US

---

DATE: November 4, 2024  
TO: Owosso City Council  
FROM: Clayton Wehner, Director of Engineering  
SUBJECT: Setting Public Hearing for Special Assessment Roll for Lynn Street Resurfacing

### RECOMMENDATION:

City staff recommends approval of Resolution No. 4 which sets the second public hearing for the Lynn Street Resurfacing Project.

### BACKGROUND:

This public hearing is intended to provide affected residents with the opportunity to comment regarding their individual assessments.

As you will recall, Step Four/Resolution No. 4 takes place after the bids are received. Estimated assessment amounts are adjusted if necessary to reflect the actual cost as dictated by the bids received. A second public hearing is set to allow property owners to comment on their particular assessment. Each property owner is sent a second notice containing the date and time of the public hearing and the amount of the proposed assessment for their property.

Step Five/Resolution No. 5 documents the second public hearing, finalizes the special assessment roll and sets the terms of payment. This public hearing is designed to allow affected citizens the opportunity to argue whether or not the amount of their assessment is fair and equitable in relation to the benefit they receive from the project. If, after hearing citizen comment, the council decides adjustments need to be made to the assessment roll they may do so. Alternately, if it is felt all the assessments are fair and equitable the resolution may be passed as written.

Tonight the council will be considering Resolution No. 4 for the proposed district as a part of the Consent Agenda. Staff recommends authorization of Resolution No. 4 setting a public hearing for Monday, November 18, 2024 to receive citizen comment regarding the proposed special assessment roll for the following public improvement:

**Special Assessment District No. 2025-02  
Lynn Street, a Public Street, from the west end to Howell Street**

for the following work:

STREET RESURFACING: WIDEN, CRUSH, SHAPE AND COMPACT EXISTING ASPHALT AND OVERLAY WITH NEW ASPHALT; GRAVEL SHOULDERS.

Attachment(s): Lynn Street Resolution No. 4  
Lynn Street Special Assessment Roll

Lynn Street Engineer's Estimate  
Lynn Street Special Assessment Map

MASTER PLAN IMPLEMENTATION GOALS: 3.4, 3.10

**RESOLUTION NO.**

**SPECIAL ASSESSMENT RESOLUTION NO. 4  
SETTING A PUBLIC HEARING  
TO RECEIVE COMMENT REGARDING  
SPECIAL ASSESSMENT DISTRICT NO. 2025-02  
LYNN STREET, A PUBLIC STREET,  
FROM THE WEST END TO HOWELL STREET**

WHEREAS, the Assessor has prepared a special assessment roll for the purpose of specially assessing that portion of the cost of the public improvements more particularly hereinafter described to the properties specially benefited by said public improvement, and the same has been presented to the Council by the City Clerk.

NOW, THEREFORE, BE IT RESOLVED THAT:

1. Said special assessment roll is hereby accepted and shall be filed in the office of the City Clerk for public examination.
2. The Council shall meet at the Owosso City Hall, Owosso, Michigan at 7:30 p.m., on Monday, November 18, 2024 for the purpose of hearing all persons interested in said special assessment roll and reviewing the same.
3. The City Clerk is directed to publish the notice of said hearings once in the *Argus Press*, the official newspaper of the City of Owosso, not less than ten (10) days prior to said hearing and shall further cause notice of said hearing to be sent by first class mail to each owner of the property subject to assessment, as indicated by the records in the City Assessor's office as shown on the general tax rolls of the City, at least ten (10) days before the time of said hearing, said notice to be mailed to the addresses shown on said general tax rolls of the City.
4. The notice of said hearing to be published and mailed shall be in substantially the following form:

**NOTICE OF HEARING  
TO REVIEW SPECIAL ASSESSMENT ROLL  
CITY OF OWOSSO, COUNTY OF SHIAWASSEE, MICHIGAN**

TO THE OWNERS OF THE FOLLOWING DESCRIBED PROPERTY:

**Lynn Street, a Public Street, from the west end to Howell Street**

TAKE NOTICE that a Special Assessment roll has been prepared for the purpose of defraying the Special Assessment district's share of the cost of the following described improvements:

**Street Resurfacing**

The said Special Assessment roll is on file for public examination with the City Clerk and any objections to said Special Assessment roll must be filed in writing with the City Clerk prior to the close of the hearing to review said Special Assessment roll.

TAKE FURTHER NOTICE that appearance and protest at this hearing is required in order to appeal the amount of the special assessment to the State Tax Tribunal if an appeal should be desired. A property owner or party in interest, his or her agent, may appear in person at the hearing to protest the special assessment or may file his or her appearance by letter and his or her personal appearance shall not be required. The property owner or any person having an interest in the property subject to the proposed special assessments may file a written appeal of the special assessment with the State Tax Tribunal

within thirty days after confirmation of the special assessment roll if that special assessment was protested at this hearing.

TAKE FURTHER NOTICE that the City Council will meet at the Owosso City Hall, Owosso, Michigan at 7:30 p.m. on Monday, November 18, 2024 for the purpose of reviewing said special assessment roll and for the purpose of considering all objections to said roll submitted in writing.



# City of Owosso

## Proposed Special Assessment No. 2025-02

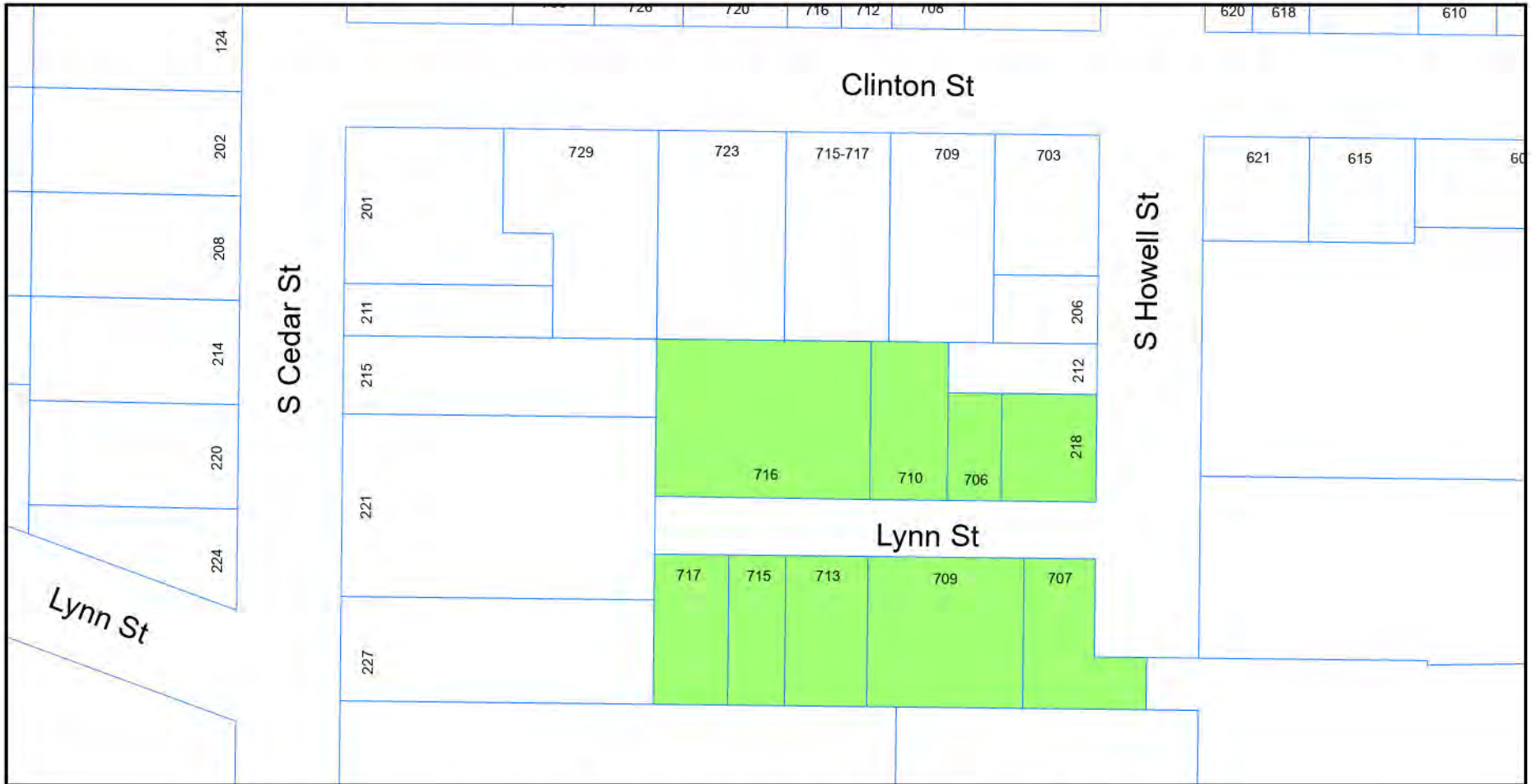

Lynn St. from West end to S. Howell St.

### Legend

- Special Assessment Parcels
- Other City of Owosso Parcels
- 1501 Street Address Number

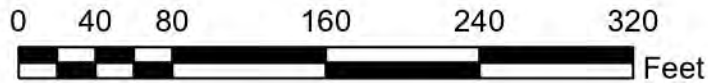

LYNN STREET FROM WEST END TO HOWELL  
LOCAL STREET

SPECIAL ASSESSMENT ROLL 2025-02

RESO 4

NORTH SIDE

ADDRESS NO.	STREET	PROPERTY OWNER NAME	ROLL NUMBER	FRONT FOOTAGE	CORNER LOT DISCOUNT	ASSESSABLE FRONT FEET	FRONT FOOT RATE	AMOUNT OF ASSESSMENT	ZONING TYPE
716	Lynn St	Rogelio Hernandez Minor	050-660-023-023-00	135	1	135.00	\$53.47	\$7,218.45	R1
710	Lynn St	Janice Nixon	050-660-023-025-00	49	1	49.00	\$53.47	\$2,620.03	R1
706	Lynn St	Vargas Family Trust	050-660-023-026-00	34	1	34.00	\$53.47	\$1,817.98	R1
218	S Howell St	Todd Thompson & Julie Birge	050-660-023-027-00	60	0.6	36.00	\$53.47	\$1,924.92	R1
				278		254.00		\$13,581.38	

SOUTH SIDE

ADDRESS NO.	STREET	PROPERTY OWNER NAME	ROLL NUMBER	FRONT FOOTAGE	CORNER LOT DISCOUNT	ASSESSABLE FRONT FEET	FRONT FOOT RATE	AMOUNT OF ASSESSMENT	ZONING TYPE
717	Lynn St	Vargas Family Trust	050-660-023-022-00	47	1	47.00	\$53.47	\$2,513.09	R1
715	Lynn St	Vargas Family Trust	050-660-023-021-00	36	1	36.00	\$53.47	\$1,924.92	R1
713	Lynn St	Richard II & Nina Devreese	050-660-023-020-00	52	1	52.00	\$53.47	\$2,780.44	R1
709	Lynn St	Alejandro Vargas	050-660-023-019-00	90	1	90.00	\$53.47	\$4,812.30	R1
707	Lynn St	Rodney Williams & Carol Reno	050-660-023-018-00	45	0.6	27.00	\$53.47	\$1,443.69	R1
				270		252.00		\$13,474.44	

TOTAL FRONT FEET: 548      TOTAL ASSESSABLE FRONT FEET: 506.00      TOTAL ASSESSMENTS: \$ 27,055.82

LYNN STREET FROM WEST END TO HOWELL STREET ENGINEER'S ESTIMATE

DESCRIPTION	QUANTITY	UNIT	UNIT PRICE	AMOUNT	ELLIGIBLE AMOUNT	CITY COST 60 PERCENT	ASSESSMENT AT 40%	
							RESIDENTIAL	COMMERCIAL
Mobilization, Max ___, (Road and Storm)	0.31	LSUM	\$ 17,195.84	\$ 5,330.71	\$ 5,330.71	\$ 3,198.43	\$ 2,132.28	\$ 2,132.28
Pavt, Rem	16	Syd	\$ 7.95	\$ 127.20	\$ 127.20	\$ 76.32	\$ 50.88	\$ 50.88
Sidewalk, Rem	13	Syd	\$ 5.47	\$ 71.11		\$ -	\$ -	\$ -
Embankment, CIP	10	Cyd	\$ 6.96	\$ 69.60		\$ -	\$ -	\$ -
Excavation, Earth	2	Cyd	\$ 9.08	\$ 18.16		\$ -	\$ -	\$ -
Subgrade Undercutting, Special	31	Syd	\$ 71.89	\$ 2,228.59		\$ -	\$ -	\$ -
Subbase, CIP	3	Cyd	\$ 34.94	\$ 104.82		\$ -	\$ -	\$ -
Aggregate Base, 9 inch, Modified	55	Syd	\$ 32.12	\$ 1,766.60		\$ -	\$ -	\$ -
HMA Base Crushing and Shaping, Modified	753	Syd	\$ 6.10	\$ 4,593.30	\$ 4,593.30	\$ 2,755.98	\$ 1,837.32	\$ 1,837.32
Asphalt Cement Stabilized Base Course, 4 inch	753	Syd	\$ 9.77	\$ 7,356.81	\$ 7,356.81	\$ 4,414.09	\$ 2,942.72	\$ 2,942.72
Asphalt Cement Binder	1204	Gal	\$ 7.33	\$ 8,825.32	\$ 8,825.32	\$ 5,295.19	\$ 3,530.13	\$ 3,530.13
Maintenance Gravel	15	Ton	\$ 39.06	\$ 585.90	\$ 585.90	\$ 351.54	\$ 234.36	\$ 234.36
Approach, CI I, LM	4	Cyd	\$ 77.06	\$ 308.24	\$ 308.24	\$ 184.94	\$ 123.30	\$ 123.30
Shld, CI I	51	Ton	\$ 44.67	\$ 2,278.17	\$ 2,278.17	\$ 1,366.90	\$ 911.27	\$ 911.27
Trenching, Modified	1.7	Sta	\$ 656.04	\$ 1,115.27		\$ -	\$ -	\$ -
Sanitary Service, Conflict	1	Ea	\$ 1,191.72	\$ 1,191.72		\$ -	\$ -	\$ -
Abandoned Gas Main, Conflict	1	Ea	\$ 463.67	\$ 463.67		\$ -	\$ -	\$ -
Dr Structure Cover, Adj, Case 1	1	Ea	\$ 610.49	\$ 610.49	\$ 610.49	\$ 366.29	\$ 244.20	\$ 244.20
Dr Structure, Temp Lowering	1	Ea	\$ 538.19	\$ 538.19	\$ 538.19	\$ 322.91	\$ 215.28	\$ 215.28
Dr Structure Cover, EJ 1040 w/ Solid Gasket Sealed Cover	1	Ea	\$ 1,010.80	\$ 1,010.80	\$ 1,010.80	\$ 606.48	\$ 404.32	\$ 404.32
HMA, 13A @ 4"	162	Ton	\$ 156.04	\$ 25,278.48	\$ 25,278.48	\$ 15,167.09	\$ 10,111.39	\$ 10,111.39
Cement	1	Ton	\$ 305.24	\$ 305.24		\$ -	\$ -	\$ -
Sidewalk, Conc, 4 inch	24	Sft	\$ 11.27	\$ 270.48		\$ -	\$ -	\$ -
Curb Ramp, Conc, 4 inch	134	Sft	\$ 20.97	\$ 2,809.98		\$ -	\$ -	\$ -
Water Shutoff, Adj, Temp, Case 1	9	Ea	\$ 341.21	\$ 3,070.89	\$ 3,070.89	\$ 1,842.53	\$ 1,228.36	\$ 1,228.36
Gate Box, Adj, Temp, Case 1	1	Ea	\$ 483.68	\$ 483.68	\$ 483.68	\$ 290.21	\$ 193.47	\$ 193.47
Minor Traf Devices, Max \$5,000	0.31	LSUM	\$ 2,079.50	\$ 644.65	\$ 644.65	\$ 386.79	\$ 257.86	\$ 257.86
Plastic Drum, Fluorescent, Furn & Oper	8	Ea	\$ 23.20	\$ 185.60		\$ -	\$ -	\$ -
Pedestrian Type II Barricade, Temp	1	Ea	\$ 152.62	\$ 152.62		\$ -	\$ -	\$ -
Turf Establishment, Performance	170	Syd	\$ 8.46	\$ 1,438.20		\$ -	\$ -	\$ -
Post, Steel, 3 lb	16	Ft	\$ 10.99	\$ 175.84		\$ -	\$ -	\$ -
Sign, Type III. Erect, Salv	1	Ea	\$ 91.57	\$ 91.57		\$ -	\$ -	\$ -
Sign, Type III, Rem	1	Ea	\$ 61.05	\$ 61.05		\$ -	\$ -	\$ -
Post, Mailbox	1	Ea	\$ 240.96	\$ 240.96		\$ -	\$ -	\$ -
<b>SUB TOTALS</b>				\$ 73,803.90	\$ 61,042.83	\$ 36,625.70	\$ 24,417.13	\$ 24,417.13
<b>ENGINEERING AT 15% ASSESSABLE COST</b>				\$ 11,070.59	\$ 9,156.42	\$ 5,493.85	\$ 3,662.57	\$ 3,662.57
<b>ADMINISTRATIVE AT 5% ASSESSABLE COST</b>				\$ 3,690.20	\$ 3,052.14	\$ 1,831.28	\$ 1,220.86	\$ 1,220.86
<b>GRAND TOTALS</b>				\$ 88,564.68	\$ 73,251.39	\$ 43,950.83	\$ 29,300.56	\$ 29,300.56

**LYNN STREET FROM WEST END TO HOWELL  
LOCAL STREET**

**SPECIAL ASSESSMENT ROLL 2025-02**

**RESO 4**

ENGINEER'S ESTIMATE ASSESSABLE AMOUNT \$73,251.39  
 TOTAL FRONT FOOTAGE 548.00

**CALCULATING ASSESSABLE FRONT FOOT RATE AND AMOUNTS:**

PROPERTY TYPE	RESIDENTIAL PROPERTY	COMMERCIAL PROPERTY	TOTAL
TOTAL ASSEMENT PER TYPE	\$73,251.39	\$73,251.39	
CITY SHARE ≥ 60%	\$43,950.83	\$43,950.83	
PROPERTY SHARE @ ≤40%	\$29,300.56	\$29,300.56	
FRONT FOOT RATE: PROP SHARE/TOTAL FRONT FOOTAGE	\$53.47	\$53.47	
TOTAL ASSESSABLE FRONT FEET PER TYPE:	506.00	0.00	
TOTAL AMOUNT OF ASSESSMENT PER TYPE:	\$27,055.82	\$0.00	\$27,055.82

**SUMMARY: SPECIAL ASSESSMENT AMOUNTS PER SIDE OF STREET:**

NORTH SIDE	\$	13,581.38
SOUTH SIDE	\$	13,474.44
TOTAL SPECIAL ASSESSMENT	\$	<u>27,055.82</u>



## MEMORANDUM

---

301 W. MAIN ▪ OWOSSO, MICHIGAN 48867-2958 ▪ WWW.CI.OWOSSO.MI.US

---

**DATE:** November 4, 2024

**TO:** Mayor Teich and the Owosso City Council

**FROM:** Ryan E. Suchanek, Director of Public Services & Utilities

**SUBJECT:** 2024-2025 DPW Inventory Parts Bid

### RECOMMENDATION:

Approval of the low responsive bid from ETNA Supply Co. (Grand Rapids, MI) for the DPW Inventory Parts Bid in the amount of \$26,905.00.

### BACKGROUND:

On October 8, 2024, the City received bids for DPW Inventory Parts. The parts are necessary for replacing, installing, and maintaining water services for the entire water distribution system. Along with regular day to day operational needs, the City also has increased needs for these parts in conjunction with the general age of the water distribution system. Additionally we are seeing extended lead times of up to eight months or longer on some of these needed parts. Thus, additional water service parts are needed in inventory. Three contractor bids were received, with ETNA Supply Co. confirmed as the low responsible bidder.

Ferguson Waterworks was the lowest bidder, however after a formal review of their bid, they did not follow the bid requirements by excluding three items, making them second for pricing the specified parts.

### FISCAL IMPACTS:

The parts will be funded by the Account No. 591-000-101.000, in the amount of \$26,905.00.

Attachments: (1) Resolution, DPW Inventory Parts Bid  
(2) Bid Tabulation, DPW Inventory Parts Bid

Master Plan Implementation Goals: 3.4

**RESOLUTION NO.**

**AUTHORIZING THE EXECUTION OF AN AGREEMENT WITH  
ETNA SUPPLY CO. FOR 2024-2025 DPW INVENTORY PARTS BID**

WHEREAS, the City of Owosso, Shiawassee County, Michigan, has determined that it is in the best interest of the public to provide stock inventory for parts needed for repairs and replacements; and

WHEREAS, these parts are required for maintenance, repair, and installation of city infrastructure. Parts and supplies which are utilized though out the entire city. Thus these additional parts are needed to help maintain our infrastructure; and

WHEREAS, the City has sufficient funds to purchase said parts from its water fund; and

WHEREAS, the City of Owosso sought bids for the DPW Inventory Parts Bid, and a bid was received from ETNA Supply Co. and it is hereby determined ETNA Supply Co. is qualified to provide said parts and that it has submitted the lowest responsible and responsive bid.

NOW THEREFORE BE IT RESOLVED by the City Council of the City of Owosso, Shiawassee County, Michigan that:

- FIRST: The City of Owosso has heretofore determined that it is advisable, necessary and in the public interest to purchase from ETNA Supply Co. for the DPW Inventory Parts Bid.
- SECOND: The Mayor and City Clerk are instructed and authorized to sign the documents for the creation of a purchase order for services between the City of Owosso, Michigan and ETNA Supply Co, in an amount not to exceed \$26,905.00.
- THIRD: The accounts payable department is authorized to pay ETNA Supply Co. for materials supplied up to the purchase order amount of \$26,905.00.
- FOURTH: The above expenses shall be paid from the account no. 591-000-101.000.

CITY OF OWOSSO BID TABULATION SHEET

DATE 10/8/2024

DEPT. DPW

2024-2025 DPW INVENTORY

Page 1

PARTS BID

Lowest Bid excluded 3 items making them 2nd

ETNA Supply Co  
4901 Clay Ave SW  
Grand Rapids, MI 49548  
616-514-5295

Ferguson Waterworks  
4040 Eagles Nest Dr  
Flushing, MI 48433  
810-691-2823

Michigan Pipe & Valve  
596 Kochville Rd  
Saginaw, MI 48604  
989-752-7911

ITEM NO.	DESCRIPTION	EST. QTY	UNIT	ETNA Supply Co		Ferguson Waterworks		Michigan Pipe & Valve	
				UNIT PRICE	TOTAL	UNIT PRICE	TOTAL	UNIT PRICE	TOTAL
1	Q14-23NL/Q34-13-NL LEAD-PAK COUPLING - NO LEAD. 1/2" DBL EXTRA STRONG LEAD or 5/8" STRONG LEAD by 3/4" CTS PACK JOINT	6	EA	\$ 37.35	\$ 224.10	\$ 38.00	\$ 228.00	\$ 45.00	\$ 270.00
2	Q14-33 OR Q34-23 NL LEAD-PAK LEAD-PAK COUPLING - NO LEAD 5/8" DBL EXTRA STRONG LEAD or 3/4" STRONG LEAD by 3/4" CTS PACK JOINT	6	EA	\$ 40.90	\$ 245.40	\$ 42.00	\$ 252.00	\$ 50.00	\$ 300.00
3	C44-34-NL COUPLING - NO LEAD 3/4" CTS PACK JOINT by 1" CTS PACK JOINT	12	EA	\$ 25.80	\$ 309.60	\$ 26.00	\$ 312.00	\$ 31.00	\$ 372.00
4	C84-33-NL C84-33-NO LEAD 3/4" MALE IRON PIPE THREAD by 3/4" CTS PACK JOINT	12	EA	\$ 18.20	\$ 218.40	\$ 19.00	\$ 228.00	\$ 22.00	\$ 264.00
5	B41-333-NL 3/4" BALL VALVE - NO LEAD 3/4" CTS PACK JOINT by 3/4" FEMALE IRON PIPE THREAD	6	EA	\$ 70.65	\$ 423.90	\$ 72.00	\$ 432.00	\$ 85.25	\$ 511.50
6	B44-444-Q-NL 1" BALL VALVE - NO LEAD 1" CTS QUICK JOINT by 1" CTS QUICK JOINT	24	EA	\$ 121.00	\$ 2,904.00	\$ 123.00	\$ 2,952.00	\$ 124.25	\$ 2,982.00
7	FB1000-7-Q-NL 2" BALL CORP - NO LEAD 2" AWWA/CC TAPER THREAD by 2" CTS QUICK JOINT	2	EA	\$ 286.50	\$ 573.00	\$ 291.00	\$ 582.00	\$ 345.00	\$ 690.00
8	B44-777-Q-NL 2" BALL VALVE- NO LEAD 2" CTS QUICK JOINT by 2" CTS QUICK JOINT	3	EA	\$ 406.95	\$ 1,220.85	\$ 413.00	\$ 1,239.00	\$ 491.00	\$ 1,473.00
				Page 1	\$ 6,119.25	Page 1	\$ 6,225.00	Page 1	\$ 6,862.50
TOTAL BID PRICING ADJUSTED FOR LOCAL PURCHASING PREFERENCE:\$2,500					N/A		N/A		N/A

**2024-2025 DPW INVENTORY**

**PARTS BID**

ETNA Supply Co  
4901 Clay Ave SW  
Grand Rapids, MI 49548  
616-514-5295

Ferguson Waterworks  
4040 Eagles Nest Dr  
Flushing, MI 48433  
810-691-2823

Michigan Pipe & Valve  
596 Kochville Rd  
Saginaw, MI 48604  
989-752-7911

ITEM #	DESCRIPTION	EST. QTY	UNIT	UNIT PRICE	TOTAL	UNIT PRICE	TOTAL	UNIT PRICE	TOTAL	
9	C44-46-Q-NL COUPLING - NO LEAD 1" CTS QUICK JOINT by 1-1/2" CTS QUICK JOINT	6	EA	\$ 60.70	\$ 364.20	\$ 62.00	\$ 372.00	\$ 74.00	\$ 444.00	
10	FS1-514-15-CC7 4IN REPAIR CLAMP/15IN LONG/2CC	1	EA	\$ 145.60	\$ 145.60	\$ 148.00	\$ 148.00	\$ 166.00	\$ 166.00	
11	FS1-724-15-CC7 6IN REPAIR CLAMP/15IN LONG/2CC	1	EA	\$ 153.95	\$ 153.95	\$ 156.00	\$ 156.00	\$ 175.00	\$ 175.00	
12	FS1-939-15-CC7 8IN REPAIR CLAMP/15IN LONG/2CC	1	EA	\$ 168.35	\$ 168.35	\$ 171.00	\$ 171.00	\$ 192.00	\$ 192.00	
13	FS1-1144-15-CC7 10IN REP CLAMP/15IN LONG/2 CC	1	EA	\$ 205.50	\$ 205.50	\$ 209.00	\$ 209.00	\$ 234.00	\$ 234.00	
14	FS1-1350-15-CC7 12IN REP CLAMP/15IN LONG/2 CC	1	EA	\$ 219.65	\$ 219.65	\$ 223.00	\$ 223.00	\$ 347.00	\$ 347.00	
15	FS2-1790-15 16IN REPAIR CLAMP/15IN LONG	1	EA	\$ 305.65	\$ 305.65	\$ 310.00	\$ 310.00	\$ 587.00	\$ 587.00	
16	FS2-1790-24 16IN REPAIR CLAMP/24IN LONG	1	EA	\$ 516.30	\$ 516.30	\$ 524.00	\$ 524.00	\$ 642.00	\$ 642.00	
17	FS2-2200-20 20IN REPAIR CLAMP/20IN LONG	2	EA	\$ 564.90	\$ 1,129.80	\$ 574.00	\$ 1,148.00	\$ 642.00	\$ 1,284.00	
18	FC2W-12-L12-Q 12IN WIDE RANGE CPLG/12IN LONG RANGE = 12.75-14.38	2	EA	\$ 460.20	\$ 920.40	\$ 467.00	\$ 934.00	\$ 523.00	\$ 1,046.00	
19	WATERMAIN PIPE 12" C909 12" PVC C909 20 FOOT LENGTH	1	EA	\$ 880.00	\$ 880.00	NO BID	\$ -	\$ 1,100.00	\$ 1,100.00	
					Page 2	\$ 5,009.40	Page 2	\$ 4,195.00	Page 2	\$ 6,217.00
<b>TOTAL BID PRICING ADJUSTED FOR LOCAL PURCHASING PREFERENCE:\$2,500</b>						N/A		N/A		N/A



**PARTS BID**

ETNA Supply Co  
4901 Clay Ave SW  
Grand Rapids, MI 49548  
616-514-5295

Ferguson Waterworks  
4040 Eagles Nest Dr  
Flushing, MI 48433  
810-691-2823

Michigan Pipe & Valve  
596 Kochville Rd  
Saginaw, MI 48604  
989-752-7911

ITEM #	DESCRIPTION	EST. QTY	UNIT	UNIT PRICE	TOTAL	UNIT PRICE	TOTAL	UNIT PRICE	TOTAL	
20	WATERMAIN PIPE 16" C909 16" PVC 20' LENGTH	1	EA	\$ 1,174.00	\$ 1,174.00	NO BID	\$ -	\$ 1,700.00	\$ 1,700.00	
21	WATERMAIN PIPE 20" C909 20" PVC 20' LENGTH	1	EA	\$ 1,817.00	\$ 1,817.00	NO BID	\$ -	\$ 1,950.00	\$ 1,950.00	
22	CAST IRON CURB BOX TOP SEC W/LID MAKED WATER 2.5" X 30" SCREW TYPE	15	EA	\$ 85.30	\$ 1,279.50	\$ 87.00	\$ 1,305.00	\$ 75.00	\$ 1,125.00	
23	CAST IRON CURB BOX BOTTOM SEC 2.5" X 40" SCREW TYPE.	15	EA	\$ 25.90	\$ 388.50	\$ 50.00	\$ 750.00	\$ 64.00	\$ 960.00	
24	CAST IRON CURB BOX EXTENTION 2.5" X 12"	6	EA	\$ 64.40	\$ 386.40	\$ 27.00	\$ 162.00	\$ 37.50	\$ 225.00	
25	EJ VALVE BOX TOP 85507026 855026T Screw Ttpe Valve Box Top 26" Tall. Black Coated	8	EA	\$ 97.30	\$ 778.40	\$ 99.00	\$ 792.00	\$ 105.00	\$ 840.00	
26	EJ VALVE BOX BOTTOM 85606030 8560 30B Screw Type Valve Box Extension #60, 30" Tall for 24" Height Adjustment, Black Coated	8	EA	\$ 82.95	\$ 663.60	\$ 84.00	\$ 672.00	\$ 89.00	\$ 712.00	
27	EJ VALVE BOX BASE 85605004 8560 #4 Valve Box Base, Black Coated	4	EA	\$ 65.35	\$ 261.40	\$ 66.00	\$ 264.00	\$ 72.00	\$ 288.00	
28	EJ 54576D Fire Hydrant 5BR250 Hydrant 5'6" MJ 1" Sq 2DTP 1-355 5" Storz Pumper 2-4 2 1/2" NST Hoses OR Yellow	1	EA	\$ 3,322.50	\$ 3,322.50	\$ 3,375.00	\$ 3,375.00	\$ 3,485.00	\$ 3,485.00	
29	6RW12 MJ VLV OR EJ 2200610 6" Resilient Wedge Gate valve MJ 2" operating Nut OR	1	EA	\$ 788.05	\$ 788.05	\$ 800.00	\$ 800.00	\$ 827.00	\$ 827.00	
30	EJ 55726D Fire Hydrant Hydrant 6' MJ 1 1/8" Pent 2DTP 1-355 5" Storz Pumper 2-4 2 1/2" NST Hoses OR Yellow	1	EA	\$ 3,384.30	\$ 3,384.30	\$ 3,438.00	\$ 3,438.00	\$ 3,550.00	\$ 3,550.00	
31	EJ 00946452 Fire Hydrant Extension 5BR250/CD250 12" HYD EXT ASY	3	EA	\$ 384.75	\$ 1,154.25	\$ 391.00	\$ 1,173.00	\$ 405.00	\$ 1,215.00	
32	BR250/CD250 Break Away Flange Repair Kit - Black	3	EA	\$ 126.15	\$ 378.45	\$ 129.00	\$ 387.00	\$ 133.00	\$ 399.00	
					Page 1 Total	\$ 6,119.25	Page 1 Total	\$ 6,225.00	Page 1 Total	\$ 6,862.50
					Page 2 Total	\$ 5,009.40	Page 2 Total	\$ 4,195.00	Page 2 Total	\$ 6,217.00
					Page 3 Total	\$ 15,776.35	Page 3 Total	\$ 13,118.00	Page 3 Total	\$ 17,276.00
					<b>Total Bid</b>	<b>\$ 26,905.00</b>		<b>\$ 23,538.00</b>		<b>\$ 30,355.50</b>





## MEMORANDUM

---

301 W. MAIN ▪ OWOSSO, MICHIGAN 48867-2958 ▪ WWW.CI.OWOSSO.MI.US

---

**DATE:** October 29, 2024  
**TO:** Owosso City Council  
**FROM:** Amy Fuller, Assistant City Manager  
**SUBJECT:** Grand Avenue Park Playground Equipment

Requesting Council approve the purchase and installation of playground equipment for Grand Avenue Park, pending grant approval, in the amount of \$37,482.67 and request council waive the competitive bid process.

Owosso City Ordinance section 2-345(3) exception to competitive bidding states: Where the council shall determine that the public interest will best be served by joint purchase with, or purchase from, another unit of government. The City of Owosso participates in the MiDeal program with the State of Michigan. MiDeal is the State of Michigan's extended purchasing program that allows Michigan municipalities to buy goods and services from state contracts. The bid meets the definition of the aforementioned Section 2-345(3) a joint purchase with another governmental unit. The State bid price from GameTime is \$37,482.67.

This purchase will include a swing set with four swings, play structure with slides, spinning toy, grill, picnic table, bench, trash can and installation of playground equipment. There is not currently any playground equipment at Grand Avenue Park. This equipment was selected and voted upon by the Parks and Recreation at their October 25, 2024 regularly scheduled meeting.

The Department of Public Works will begin site preparation during the spring of 2025. The purchase is being requested now due to expectation of increased costs in 2025.

This project will be funded by a \$15,000 Neighborhood Enhancement Program (NEP) Grant, \$15,000 from the city's general fund and \$15,000 from the Parks and Recreation millage account 208-751-930.000. This contract is to be completed by June 30, 2025.

Attachments: (1) GameTime c/o Sinclair Recreation Proposal  
(2) GameTime Contract #180000001296

Master Plan Implementation Goals: 5.2, 5.3

**RESOLUTION NO.**

**RESOLUTION AUTHORIZING THE PURCHASE OF PLAYGROUND EQUIPMENT  
FROM GAMETIME VIA  
STATE OF MICHIGAN MIDEAL CONTACT #180000001296**

WHEREAS, the City of Owosso, Shiawassee County, Michigan, has a Parks and Recreation Commission requiring the purchase of playground equipment; and

WHEREAS, the City of Owosso may waive competitive bidding requirements when purchasing equipment in coordination with another municipality.

WHEREAS, the City of Owosso desires to purchase playground equipment from GameTime, holder of the MiDeal contract #180000001296 with the State of Michigan; and it is hereby determined that GameTime is qualified to provide such equipment and that it has submitted the responsible and responsive bid; and

NOW THEREFORE BE IT RESOLVED by the City Council of the City of Owosso, Shiawassee County, Michigan that:

- FIRST: The City of Owosso has theretofore determined that it is advisable, necessary and in the public interest to purchase playground equipment, utilizing GameTime Contract No. #180000001296, for a cost to the City of Owosso of \$37,482.67.
- SECOND: The Finance Director and the City Manager are hereby instructed and authorized to sign necessary documents to complete the purchase as soon as the Neighborhood Enhancement Program (NEP) grant agreement is finalized.
- THIRD: Authorize payment to GameTime in the amount of \$37,482.67 upon delivery of the playground equipment.
- FOURTH: The above expenses shall be paid from the general fund 101-751-930.000 in the amount of \$22,482.67 and \$15,000 from the Parks Millage Fund account 208-751-930.000.



# STATE OF MICHIGAN

Dept. of Natural Resources - Procurement Services  
 PO Box 30028  
 525 West Allegan St.  
 Lansing, MI 48909

## CONTRACT CHANGE NOTICE

Change Notice Number **4**  
 to  
 Contract Number **180000001296**

<b>CONTRACTOR</b>	PlayCore Wisconsin, Inc., dba GameTime
	150 Playcore Drive SE
	Fort Payne, Alabama 35967
	Clint Whiteside
	423-425-3162
	Clint.whiteside@gametime.com
	Michigan Vendor #CV0049895

<b>STATE</b>	Program Manager	James Gallie	DNR
		231-843-7015	
	galliej@michigan.gov		
	Contract Administrator	Patrick Avendt	DNR
517-388-6265			
avendtp@michigan.gov			

CONTRACT SUMMARY				
<b>DESCRIPTION:</b> Furnish, deliver and install commercial playground equipment, outdoor fitness equipment, and Americans with Disabilities Act-approved surfacing in state parks across the State of Michigan.				
INITIAL EFFECTIVE DATE	INITIAL EXPIRATION DATE	INITIAL AVAILABLE OPTIONS	EXPIRATION DATE BEFORE CHANGE(S) NOTED BELOW	
7/19/2018	6/30/2022	2 – 2 year	6/30/2024	
PAYMENT TERMS		DELIVERY TIMEFRAME		
Net 45 FOB		As specified on Delivery Order		
ALTERNATE PAYMENT OPTIONS			EXTENDED PURCHASING	
<input type="checkbox"/> P-card <input type="checkbox"/> Payment Request (PRC) <input type="checkbox"/> Other			<input type="checkbox"/> Yes <input type="checkbox"/> No	
MINIMUM DELIVERY REQUIREMENTS				
Payment is processed through standard Delivery Orders to the PlayCore dealer network.				
DESCRIPTION OF CHANGE NOTICE				
OPTION	LENGTH OF OPTION	EXTENSION	LENGTH OF EXTENSION	REVISED EXP. DATE
<input checked="" type="checkbox"/>	2 Years	<input type="checkbox"/>		6/30/2026
CURRENT VALUE		VALUE OF CHANGE NOTICE	ESTIMATED AGGREGATE CONTRACT VALUE	
\$499,000.00		\$850,000.00	\$1,349,000.00	
<b>DESCRIPTION:</b> The State is exercising the second of two 2-year options. The revised contract expiration date after this change notice is 6/30/2026. Adding \$850,000.00. New aggregate total value of the contract is \$1,349,000.00. All other terms and conditions to the contract remain unchanged, including the Michigan MiDeal Program terms and conditions.				

**FOR THE CONTRACTOR:**

\_\_\_\_\_  
**Company Name**

\_\_\_\_\_  
**Authorized Agent Signature**

\_\_\_\_\_  
**Authorized Agent** (Print or Type)

\_\_\_\_\_  
**Date**

**FOR THE STATE:**

\_\_\_\_\_  
**Signature**

\_\_\_\_\_  
**Name & Title**

\_\_\_\_\_  
**Agency**

\_\_\_\_\_  
**Date**



GameTime c/o Sinclair Recreation  
 176 E Lakewood Blvd  
 Holland, MI 49424  
 Ph: 800-444-4954  
 Fax: 616-392-8634

08/19/2024  
 Quote #  
 106481-01-03

## GameTime Playground Equipment - With Installation

City Of Owosso  
 Attn: Amy Fuller  
 301 W. Main St.  
 Owosso, MI 48867  
 UNITED STATES  
 Phone: 989-725-0577  
 amy.fuller@ci.owosso.mi.us

Ship to Zip 48867

Quantity	Part #	Description	Unit Price	Amount
1	11889	GameTime - PrimeTime Fontana	\$21,405.00	\$21,405.00
1	6310	GameTime - G6	\$3,039.00	\$3,039.00
1	RDU	GameTime - Swings with Seats	\$5,140.00	\$5,140.00
		(1) P8544 -- Ada 8' Ht Swing Frame, 3 1/2" Toprail		
		(1) P8548 -- Ada 8' Ht Add-A-Bay, 3 1/2" Toprail		
		(2) SS8910 -- Belt Seat 3 1/2" /8' W/Clevis		
		(1) SS8537 -- Adaptive Seat (3 1/2" /8' High)		
		(1) SS8696 -- Encl Tot Seat 3 1/2"/8' High W/Clevis		
1	51	GT-Site - Economy Stove Permanent	\$395.00	\$395.00
1	T110	GT-Site - 32 GAL DURACLAD RECEPTACLE SM	\$995.00	\$995.00
1	T108S	GT-Site - 6' DURACLAD BENCH W/BACK THERMOCOAT S	\$852.00	\$852.00
1	P1309	GT-Site - H.D. Accessible Picnic Table W/ Wood	\$1,237.00	\$1,237.00
1	INSTALL	GameTime - Installation of GameTime Equipment	\$10,000.00	\$10,000.00
1	INSTALL	GameTime - Unloading of equipment	\$750.00	\$750.00
Contract: OMNIA #2017001134			Sub Total	\$43,813.00
			Discount	(\$8,771.30)
			Freight	\$2,440.97
			<b>Total</b>	<b>\$37,482.67</b>

### Comments

Price does not include site preparation or excavation, supply or installation of safety surfacing, site restoration or landscaping  
 This quotation is subject to policies in the current GameTime Playground Catalog and the following terms and conditions. Our quotation is based on shipment of all items at one time to a single destination, unless noted, and changes are subject to price adjustment. Purchases to be supported by your written purchase order made out to GAMETIME C/O SINCLAIR RECREATION. A 2.5% PROCESSING FEE WILL BE ADDED T O ALL ORDERS PAID VIA CREDIT CARD.

Pricing: f.o.b. factory, firm for 30 days from date of quotation unless otherwise noted on quotation. Sales tax will be added at time of invoicing unless a tax exemption certificate is provided at time of order entry.

Payment terms: Net 30 days for tax supported governmental agencies. A 1.5% per month finance charge will be imposed on all past due accounts. Equipment shall be invoiced separately from other services and shall be payable in advance of those services and project completion. Retainage not accepted.





GameTime c/o Sinclair Recreation  
176 E Lakewood Blvd  
Holland, MI 49424  
Ph: 800-444-4954  
Fax: 616-392-8634

08/19/2024  
Quote #  
106481-01-03

## GameTime Playground Equipment - With Installation

Shipment: Order shall ship within 6-8 weeks after GameTime's receipt and acceptance of your purchase order, color selections, approved submittals, and receipt of deposit, if required.

Installation: Shall be by a Certified GameTime Installer. Customer shall be responsible for scheduling coordination and site preparation. Site should be level and permit installation equipment access. Purchaser shall be responsible for unknown conditions such as buried utilities, tree stumps, bedrock or any concealed materials or conditions that may result in additional labor or material costs. Payment terms for installation is Net 10 Days.

**NOTE:** PRICING DOES NOT INCLUDE ANY DAVIS BACON OR PREVAILING WAGE RATES UNLESS SPECIFICALLY IDENTIFIED ABOVE IN QUOTE. THERE WILL BE A BACKCHARGE FOR THE INSTALLATION TO BE DONE THROUGH FELT, PEASTONE, SURFACING, OR WOODCHIPS, UNLESS SPECIFICALLY LISTED IN ABOVE QUOTE.

Exclusions: Unless specifically included, this quotation excludes all site work and landscaping; removal of existing equipment; acceptance of equipment and off-loading; storage of goods prior to installation; equipment assembly and installation; safety surfacing; borders, drainage provisions, or any local/municipal permits or paperwork that may be required.





GameTime c/o Sinclair Recreation
176 E Lakewood Blvd
Holland, MI 49424
Ph: 800-444-4954
Fax: 616-392-8634

08/19/2024
Quote #
106481-01-03

GameTime Playground Equipment - With Installation

Acceptance of quotation:

Accepted By (printed): \_\_\_\_\_

P.O. No: \_\_\_\_\_

Please make P.O.s out to GameTime C/O Sinclair Recreation

Signature: \_\_\_\_\_

Title: \_\_\_\_\_

Date: \_\_\_\_\_

Facsimile: \_\_\_\_\_

Phone: \_\_\_\_\_

Email: \_\_\_\_\_

Purchase Amount: \$37,482.67

REQUIRED ORDER INFORMATION:

Bill To: \_\_\_\_\_

Ship To: \_\_\_\_\_

Contact: \_\_\_\_\_

Contact: \_\_\_\_\_

Address: \_\_\_\_\_

Address: \_\_\_\_\_

Address: \_\_\_\_\_

Address: \_\_\_\_\_

City, State, Zip: \_\_\_\_\_

City, State, Zip: \_\_\_\_\_

Tel: \_\_\_\_\_

Tel: \_\_\_\_\_

(For Accounts Payable)

(To call before delivery)

Email: \_\_\_\_\_

Email: \_\_\_\_\_

COLOR SELECTIONS: \_\_\_\_\_

SALES TAX EXEMPTION CERTIFICATE #: \_\_\_\_\_ (PLEASE PROVIDE A COPY OF CERTIFICATE)

NOTE: IF INSTALLATION IS BEING QUOTED, THERE WILL BE A BACKCHARGE FOR THE INSTALLATION TO BE DONE THROUGH FELT, PEASTONE, SURFACING, OR WOODCHIPS. PRICING VALID FOR 30 DAYS FROM THE DATE OF QUOTATION UNLESS OTHERWISE NOTED. ANY MODIFICATIONS TO AN ACCEPTED QUOTATION MUST BE DOCUMENTED IN WRITING OR WITH A NEW OR SEPARATE QUOTE. VERBAL MODIFICATIONS TO PREVIOUSLY SIGNED QUOTES WILL NOT BE ACCEPTED.





301 W. MAIN • OWOSSO, MICHIGAN 48867-2958 • (989) 725-0599 • FAX (989) 723-8854

---

# *MEMORANDUM*

---

DATE: October 28, 2024

TO: City Council

FROM: Kevin Lenkart  
Director of Public Safety

RE: Traffic Control Order # 1523

---

Lizzie Frederick, Owosso Main Street Director, is requesting the following street/lot closure for the annual Downtown Glow Parade, 5K and Tree Lighting. The City insurance policy will cover this event.

**LOCATIONS/DATES/TIMES:**

**12:00 p.m. to 10:00 p.m., Friday, November 29, 2024**

Main Street Plaza

**3:00 p.m. to 7:00 p.m., Friday, November 29, 2024**

Exchange Street from Washington Street to Water Street; Water Street from Exchange Street to North Street; North Street from Exchange Street to entrance of Owosso High School

**6:00 p.m. to 9:00 p.m., Friday, November 29, 2024**

Washington Street from King Street to Jerome Ave

The Public Safety Department has issued Traffic Control Order #1523 in accordance with the Rules

for the Issuance of Certain Traffic Control Orders. Staff recommends approval and further authorization of a traffic control order formalizing the action.

<b>Master Plan Implementation Goals</b>	
4.5 - Identify, Preserve and Enhance the Community's Character	Continue to support biking, walking and river activities in downtown.
4.6 - Identify, Preserve and Enhance the Community's Character	Continue to support festivals and events.
4.16 - Identify, Preserve and Enhance the Community's Character	Promote tourism. Advance and expand Downtown's Day-Tripper Transformation Strategy.
5.9 - Increase Quality of Life and Quality of Place for All	Increase lifestyle, entertainment options including festivals and cultural events.
5.12 - Increase Quality of Life and Quality of Place for All	Continue to support weekend and evening activities in the downtown.
5.17 - Increase Quality of Life and Quality of Place for All	Create and demonstrate a welcoming culture of hospitality for the vision, businesses and residents of Downtown Owosso.

**CITY OF OWOSSO**  
**TRAFFIC CONTROL ORDER**

*(SECTION 2.53 UNIFORM TRAFFIC CODE)*

---

ORDER NO.:	DATE:	TIME:
1523	10/27/2024	10:00 am

---

REQUESTED BY:  
Kevin Lenkart – Director of Public Safety

---

TYPE OF CONTROL:  
Street/Lot Closure

---

LOCATION OF CONTROL:

**12:00 p.m. to 10:00 p.m., Friday, November 29, 2024**

Main Street Plaza

**3:00 p.m. to 7:00 p.m., Friday, November 29, 2024**

Exchange Street from Washington Street to Water Street; Water Street from Exchange Street to North Street; North Street from Exchange Street to entrance of Owosso High School

**6:00 p.m. to 9:00 p.m., Friday, November 29, 2024**

Washington Street from King Street to Jerome Ave

---

EVENT:

Glow Parade, 5k and Tree Lighting

DATE: November 29, 2024

TIME: 5:00 pm – 9:00 pm

---

APPROVED BY COUNCIL

\_\_\_\_\_, 20 \_\_\_\_

---

REMARKS:



APPLICATION FOR USE OF CITY STREETS & PARKING LOTS FOR SPECIAL EVENTS

202 S. WATER STREET · OWOSSO, MICHIGAN 48867-2958 · (989) 725-0580 · FAX 725-0528

This application, plus all required documentation and fees shall be submitted to the Public Safety Department at least thirty (30) days and not more than one hundred twenty (120) days prior to the first day of the requested event, with 2 exceptions:

- 1. Applicants requiring the issuance of a conditional use permit as required by Sec. 38-504(4)(b), shall submit a complete application at least ninety (90) days prior to the event.
2. Applicants requesting the use of a state trunkline shall submit a complete application at least forty-five (45) days prior to the event.

Event Name: \_\_\_\_\_

Applicant Name: \_\_\_\_\_ Date: \_\_\_\_\_
(Individual or Group Name)

Primary Contact: \_\_\_\_\_ Title: \_\_\_\_\_

Address: \_\_\_\_\_

Phone: \_\_\_\_\_ Email: \_\_\_\_\_

Requested Date(s): \_\_\_\_\_ Requested Hours: \_\_\_\_\_
(Including set-up and clean-up)

Area Requested (Parking Lot - Parade Route): \_\_\_\_\_

Detailed description of the use for which the request is made: \_\_\_\_\_

Please attach the following items and mark the corresponding checkbox indicating their inclusion. See back for detailed descriptions of each item:

- Executed Hold Harmless Agreement
Map of the Event Area with Event location highlighted
Rules or policies applicable to persons participating in proposed event
Proof of Insurance
or
Request for Insurance Waiver
Application Fee

Continued on back...

**INDEMNIFICATION AND HOLD HARMLESS AGREEMENT.** In consideration of the granting of permission by the City of Owosso to the Applicant for the use of facilities set forth above, Applicant shall indemnify, defend and hold harmless the City of Owosso, their officials, employees, agents, professionals and volunteers, collectively (“CITY”) from and against any and all claims, losses, penalties, damages, settlements, costs, charges, professional fees (including attorneys’ fees and related costs) and/or other expenses or liabilities of any nature whatsoever including, without limitation, the investigation and defense of any claims, arising out of or resulting from the conduct of the activities for which this application is made, and for the use of the facilities and any other facilities which are employed by the Applicant, or their guests, during the period for which the facilities requested are used, provided that any such claim, damage, loss, or expense (a) is attributable to bodily injury, sickness, disease or death, or to injury or to destruction of tangible property including the loss of the use resulting there from, and (b) is caused in whole or in part by any negligent act or omission of the Applicant, or anyone directly or indirectly employed by them, or anyone for whose acts they may be liable, regardless of whether it is caused in part by a party indemnified hereunder.

The Applicant certifies that s/he has read and examined this application and that all information contained herein is true and correct. Applicant agrees to observe all City ordinances, laws and/or conditions imposed.

Applicant Signature: \_\_\_\_\_ Date: \_\_\_\_\_

**Information Regarding Required Documents**

Map of the Event Area – Map showing the general area where the event will be located. The exact event location /event route must be highlighted and the locations requiring barricades for the requested street/lot closure must be clearly marked.

Rules or policies - Rules and policies applicable to events and activities organized in such a manner as to constitute an invitation to members of the general public to participate in the event or activity shall comply with all applicable local, state and federal laws and regulations and shall include, at a minimum, a process for appealing decisions that have the effect of denying participation or imposing limitations on participation beyond those generally applicable to all other participants.

Proof of Insurance – A Certificate of Insurance and Endorsement acceptable to the City evidencing General Liability insurance for the event in the minimum amount of \$1,000,000 per occurrence. Coverage shall be endorsed to name the City of Owosso as additional insured and be primary and non-contributory to any other insurance the City has.

or

Request for Insurance Waiver - The City Council may waive the insurance requirement if it determines that insurance coverage is unavailable or cannot be obtained at a reasonable cost and the event or activity is in the public interest or fulfills a legitimate and recognized public purpose. Check box if you are requesting waiver of insurance.

*Applicants must indicate whether they are providing proof of insurance or requesting an insurance waiver. Request for a waiver in no way guarantees a waiver will be granted.*

Application Fee – Fee set by resolution of City Council to offset a portion of the costs related to the processing of special events applications.

- \$30 Application (30-120 days prior to 1<sup>st</sup> day of event)  Additional: \_\_\_\_\_
- \$50 Additional MDOT Closure (M-21, M-71, M-52)  Additional: \_\_\_\_\_
- \$15 Additional-Expedited Fee (14-29 days prior to 1<sup>st</sup> day of event)  Additional: \_\_\_\_\_

**\$ \_\_\_\_\_ Total Due at Time of Application. Please make check payable to: City of Owosso.**

.....  
Do Not Write Below This Line - For Officials Use Only

Approved  Not Approved  Date: \_\_\_\_\_ Traffic Control Order Number \_\_\_\_\_

Copy of Rules & Regulations provided to Applicant

Cc: DDA – Director; WCIA – Chairperson

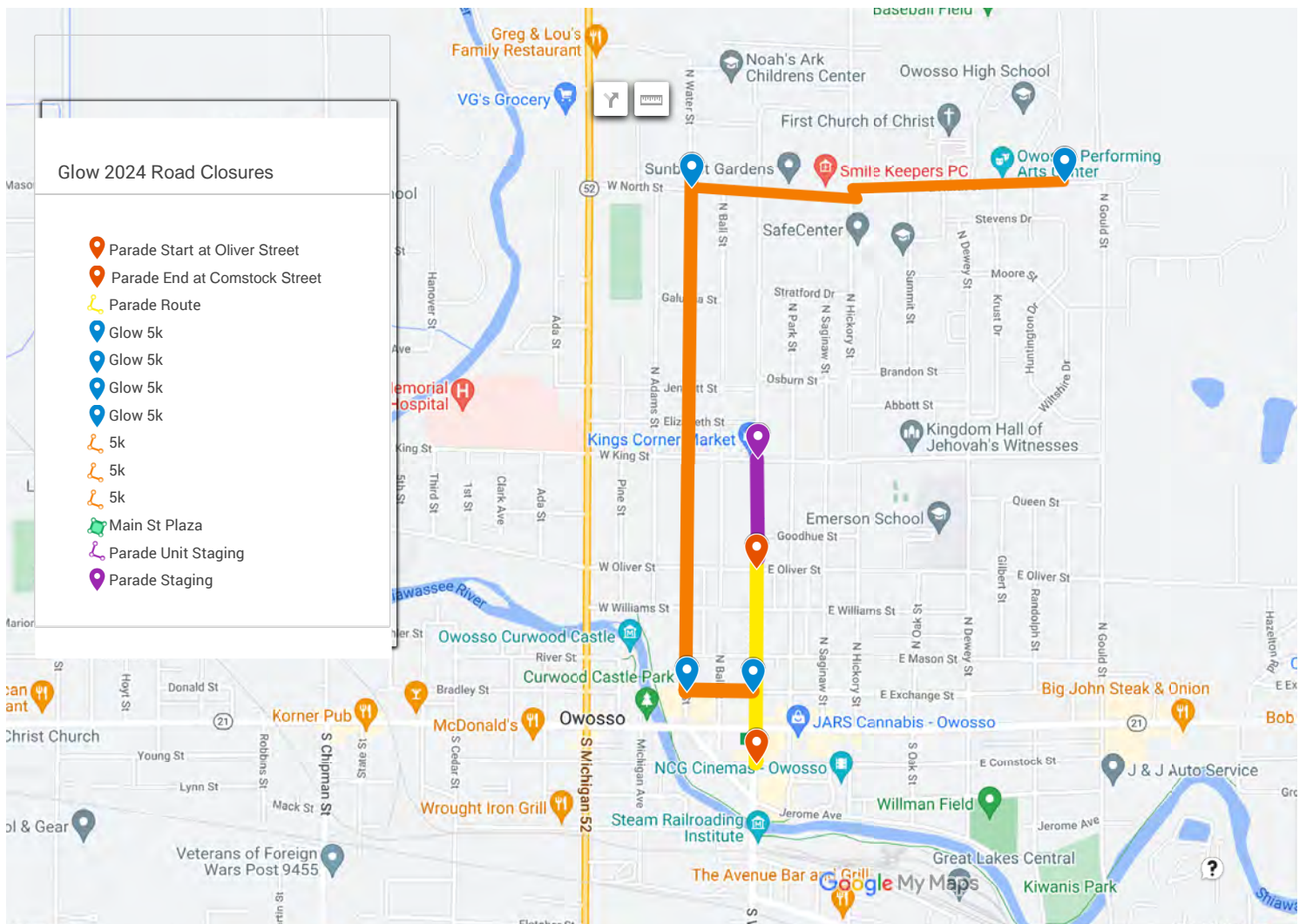

## Glow Owosso Event Rules & Regulations

- This event is free to attend
- Participation in the 5k includes a registration fee
- Parade unit registration is free
- The City of Owosso and the Owosso Main Street & Downtown Development Authority does not assume liability for any entries made into the parade

The OMS & DDA is committed to a work environment in which all individuals are treated with respect and dignity. Every individual has the right to work in a professional atmosphere that provides equal employment opportunities and prohibits discriminatory practices. We expect all vendors, staff, volunteers, and representatives of the OMS & DDA to be professional and welcoming.

No vendor shall refuse to permit the purchase of any product or service based on race, religion, color, gender, political affiliation, sexual orientation, national origin, sex, age, gender-identity, height, weight or mental/physical ability. Harassment in any form will not be tolerated. Any vendor, staff member, volunteer or OMS & DDA representative experiencing or witnessing any form of harassment or discrimination must report it immediately to the Event Lead and OMS & DDA Executive Director.

All OMS & DDA events are non-smoking.

All City of Owosso ordinances apply to OMS & DDA events.

### 5K ROUTE

Exchange Street from Water to Washington

Water Street from Exchange to North

North Street from Water to Gould

### PARADE ROUTE

Washington Street from Oliver to Comstock

### 5KVOLUNTEER LIST

- Volunteer with Flag/Light

1 @ Exchange & Water

1 @ Mason & Water

2 @ Water & Williams

2 @ Water & Oliver

2 @ Water & King

1 @ Water & Jennett

1 @ Water & Galusha

2 @ Water & North

1 @ North & Ball

2 @ North & Washington

2 @ North & Hickory

1 @ North & Summit

1 @ North & Rublman

1 @ North & Krust

2 @ High School Turnaround/Water Station





## MEMORANDUM

---

301 W. MAIN ▪ OWOSSO, MICHIGAN 48867-2958 ▪ WWW.CI.OWOSSO.MI.US

---

**DATE:** November 4, 2024

**TO:** Mayor Teich and the Owosso City Council

**FROM:** Ryan E. Suchanek, Director of Public Services & Utilities

**SUBJECT:** Bulk Polymer Havaflock 560

### RECOMMENDATION:

Authorization to enter into a purchase agreement with Haviland Products Company of Grand Rapids, Michigan for bulk polymer necessary for condition wastewater sludge.

### BACKGROUND:

As part of the Wastewater Treatment Plant (WWTP) Solids Handling Project, new equipment was installed to dewater the liquid sludge generated by the plant settling processes. Part of the dewatering process involves adding a polymer solution to the sludge prior to injection into the dewatering equipment.

WWTP staff sought out polymer suppliers to provide us with product recommendations based on bench tests. These tests were conducted in Summer/Fall 2023, with polymers from three suppliers: Haviland Products Company (Grand Rapids, MI), Brenntag (Reading, PA) and Polydyne (Riceboro, GA). The results indicated the most cost-effective product would be Havaflok 560 from Haviland Products Company. While it did not have the lowest cost per lb., the bench testing showed a lower expected usage rate. Thus it was decided this would be the polymer we would use to start up the new process, and evaluate it over time under the varying conditions of the sludge.

At this point, the new sludge process has been operational since March of this year. While the polymer usage is more than expected, it is working well with the entire system to produce an excellent quality of dewatered sludge, with higher than expected percent solids that results in reduced landfill fees. Additionally, optimizing the polymer dosing within the system is a complex, ongoing process, so the usage may decrease over time as efficiencies are increased.

Haviland Products Company is a sole source provider for a polymer called Havaflock 560. Request waiver of purchasing policy formal bid requirements in order to initiate immediate procurement upon approval and authorization. The purpose of this polymer is to condition wastewater sludge for dewatering at the Wastewater Treatment Plant.

**FISCAL IMPACTS:**

Estimated \$31,758.00 expense for the remainder of the fiscal year. Funded from the Operations & Maintenance Budget account 599-548-743.200.

**Document originated by:** Ryan E. Suchanek, Director of Public Services & Utilities

**Attachments:** (1) Polymer Price Quotations  
(2) Resolution

Master Plan Implementation Goals: 3.4.

**RESOLUTION NO.**

**RESOLUTION AUTHORIZING THE EXECUTION OF A PURCHASE ORDER  
FOR HAVAFLOCK 560 WITH HAVILAND PRODUCTS COMPANY**

WHEREAS, the City of Owosso, Shiawassee County, Michigan, requires Havaflock 560 in bulk deliveries for use in conditioning wastewater sludge for dewatering at the Wastewater Treatment Plant; and

WHEREAS, the City of Owosso has determined that Haviland Products Company of Grand Rapids, Michigan is the only firm qualified to provide the Havaflock 560 product for conditioning wastewater sludge for dewatering at the Wastewater Treatment Plant; and

WHEREAS, waiver of the purchasing policy formal Bid requirements is requested, in order to initiate procurement upon approval and authorization.

NOW THEREFORE BE IT RESOLVED by the City Council of the City of Owosso, Shiawassee County, Michigan that:

FIRST: The City of Owosso has theretofore determined that it is advisable, necessary and in the public interest to purchase Havaflock 560 from Haviland Products Company, at the price of \$2.26 per pound (plus delivery fee) with an estimated semi-annual usage of 13,800 pounds.

SECOND: The accounts payable department is authorized to submit payment to Haviland Products Company of Grand Rapids, Michigan, the estimated amount of \$31,758.00, which may exceed based on usage and actual need, for FY2024-2025.

THIRD: The above expenses shall be paid from the WWTP fund following delivery, and chargeable to account 599-548-743.200.

**From:** [Darlene Devereaux](#)  
**To:** [Timothy J. Guysky](#)  
**Subject:** RE: Prices for Havaflok 560  
**Date:** Tuesday, January 23, 2024 2:27:44 PM  
**Attachments:** [image001.png](#)  
[image002.png](#)

---

Tim

Prices:

Havaflok 560  
2300/lb. totes  
\$2.26/lb. (\$5,198.00/per tote)

Please call Chad from Petoskey WWTP 231-758-4868 they use this product.

We are putting the same product into 1-2 other WWTP in the next couple of weeks.

Thanks

**Darlene Devereaux** | Technical Sales Account Manager

**Haviland Products Company**

421 Ann St. N.W. | Grand Rapids, MI 49504

**C** | 517.719.1140

**F** | 616.361.9772

**ORDERS** | 800.627.2111

**W** | [www.havilandusa.com](http://www.havilandusa.com)



---

**From:** Timothy J. Guysky <[timothy.guysky@ci.owosso.mi.us](mailto:timothy.guysky@ci.owosso.mi.us)>

**Sent:** Tuesday, January 23, 2024 10:11 AM

**To:** Darlene Devereaux <[darlened@havilandusa.com](mailto:darlened@havilandusa.com)>

**Subject:** RE: Polymer reports

**From:** [Jeffrey Cruse/Great Lakes/Brenntag](#)  
**To:** [Timothy J. Guysky](#)  
**Cc:** [Tyler Alleman/BSI/Brenntag](#)  
**Subject:** FW: Owosso Polymer  
**Date:** Thursday, June 8, 2023 11:59:00 AM  
**Attachments:** [image001.png](#)  
[Owosso WWTP - Jar Test Report Polymer\\_060223.pdf](#)

---

Hi Tim,

Thanks again for letting us in last week. Attached is the report and pricing. If you have any questions let us know.

Jeff

---

**From:** Tyler Alleman/BSI/Brenntag <Tyler.Alleman@brenntag.com>  
**Sent:** Friday, June 2, 2023 4:16 PM  
**To:** Jeffrey Cruse/Great Lakes/Brenntag <Jeffrey.Cruse@brenntag.com>  
**Cc:** Douglas J. Arlow/Northeast/Brenntag <Douglas.Arlow@brenntag.com>  
**Subject:** Owosso Polymer

Hey Jeff,

Here is the report on the polymer jar testing we did. The product I recommend is:

**Superfloc SD-2081**

- Product Code: TBD
- Product Size: 1050 kg tote (2310 lbs / 275 gallons)
- Sell Price Delivered: \$2.288/#
- Lead time: 2-3 weeks

Thanks,

**Tyler Alleman**

Water Treatment Specialist  
Brenntag Specialties – Water Treatment



**Brenntag Specialties**

4801 S Austin Ave  
Chicago, IL 60638

Mobile: +1-847-450-3983

E-Mail: [talleman@brenntag.com](mailto:talleman@brenntag.com)

[www.brenntag.com](http://www.brenntag.com)

[LinkedIn](#) · [Facebook](#) · [Twitter](#) · [YouTube](#)



6/20/2023

Mr. Timothy Guysky  
City of Owosso  
1410 Chippewa Trail Owosso, MI 48867

**RE: Polymer Price Quotation**

Dear Mr. Guysky,

Polydyne, Inc. is pleased to offer you the following price quotation:

PRODUCT	UNIT PRICE	PACKAGE
<b>Clarifloc C-6267</b>	<b>\$1.83/LB. DELIVERED</b>	<b>2300LB. Tote</b>

**Quotation Period:** This price remains firm for the period 7/1/23 – 6/30/24.

If you have any questions, feel free to call me at (330) 671-4686. To place an order, please call our Customer Service department at (800) 848-7659.

Sincerely,

Steve Wise  
Technical Sales Representative  
Polydyne, Inc.



## MEMORANDUM

---

301 W. MAIN ▪ OWOSSO, MICHIGAN 48867-2958 ▪ WWW.CI.OWOSSO.MI.US

---

**DATE:** November 4, 2024

**TO:** Mayor Teich and the Owosso City Council

**FROM:** Ryan E. Suchanek, Director of Public Services & Utilities

**SUBJECT:** WWTP Secondary Clarifier Project Change Order #1

### RECOMMENDATION:

Approval of increased payment for construction work by RCL Construction Co., Inc. (Sanford, MI) for the WWTP Secondary Clarifier project in the amount of \$76,000.00.

### BACKGROUND:

The Wastewater Treatment Plant has two existing rectangular clarifiers originally installed in 1930s for primary clarification. The clarifiers are only designed to handle average day loading, they do not meet depth requirements for secondary treatment, and are in very poor condition.

One new circular clarifier will be constructed and sized to one half the maximum day. It will be installed east of the existing rectangular clarifier and connected into existing site piping. Electrical, SCADA, and site lighting will be connected in the main plant building. The existing rectangular clarifiers will remain in service for wet weather events and redundancy. The existing drying beds will need to be removed during construction and two new drying beds will be installed to the south of the proposed clarifier.

Key components of the clarifiers have reached or are beyond the end of their useful lives. The proposed project is intended to address the critical clarifiers' issues of aging infrastructure at the WWTP, and increase the longevity of the WWTP.

City Council previously approved the start to this project at its regular scheduled meeting held on November 6, 2023.

On June 17, 2024, the City received bids for the WWTP Secondary Clarifier Project. Base Bid plus Alternate 3 ranged from \$5,773,100 to \$6,689,000.

On July 15, 2024, City Council approved the low responsive bid from RCL Construction Co., Inc. (Sanford, MI) for the WWTP Secondary Clarifier in the amount of \$5,773,100.00.

Recently staff and engineers have reviewed current and future items, in order to seek out

efficiencies in order to combine and save on both work (mobilization, labor, equipment, and etc.) and materials/items as to prep and prevent the need to rework items and areas on future work. Ultimately to save and reduce long range costs. Including the Drying Bed Drain Line, which includes:

- Revising fence and asphalt demolition and restoration limits north end of site along Drying Bed Drain Line.
- Upsize Drying Bed Drain Line to be 18" PVC SDR26 pipe. Revise routing for drain line and add Sanitary Manhole-202. Revise slopes and downstream tie-in elevation of drain line.

#### **FISCAL IMPACTS:**

The project is funded by the CWSRF, with the additional costs of \$76,000.00. Final expenses in the amount of \$5,849,100.00 shall be paid from wastewater operating fund and 2024 SRF Bond funds.

**Document originated by:** Ryan E. Suchanek, Director of Public Services & Utilities

ATTACHMENTS:     (1)     Resolution  
                          (2)     Change Order

Master Plan Implementation Goals: 3.4, 3.7.



**RESOLUTION NO.**

**AUTHORIZING CHANGE ORDER NO. 1  
TO THE CONTRACT BETWEEN THE CITY OF OWOSSO AND  
RCL CONSTRUCTION, INC. OF SANFORD, MICHIGAN FOR  
CONSTRUCTION AND INSTALLATION OF SECONDARY CLARIFIER FOR  
USE AT THE WASTEWATER TREATMENT PLANT**

WHEREAS, the City of Owosso, Shiawassee County, Michigan, approved a contract with RCL Construction Co., Inc., on July 15, 2024 for the construction and installation of the Secondary Clarifier equipment, known as the Wastewater Treatment Plant (WWTP) Secondary Clarifier Project, are approved 2024 SRF planned project; and

WHEREAS, the project is now underway and a change order is necessary to reconcile contract work and supplies to be used.

NOW THEREFORE BE IT RESOLVED by the City Council of the City of Owosso, Shiawassee County, Michigan that:

- FIRST: The City of Owosso has heretofore determined that it is advisable, necessary and in the public interest to amend the Wastewater Treatment Plant (WWTP) Secondary Clarifier Project contract with RCL Construction Co., Inc. to increase the contract amount to update contract work and supplies to be used.
- SECOND: The Mayor and City Clerk are instructed and authorized to sign the document substantially in form attached as Change Order No. 1 in the amount of \$76,000.00; an increase to the Contract for Services between the City of Owosso and RCL Construction Co., Inc., revising the total current contract amount from \$5,773,100.00 to \$5,849,100.00.
- THIRD: The Accounts Payable department is authorized to pay RCL Construction Co., Inc. for work satisfactorily completed up to the revised contract amount of \$5,849,100.00.
- FOURTH: The above expenses shall be paid from the Wastewater Fund, and SRF Bond Funds

CHANGE ORDER  
 PAGE 1 OF 2

<b>CONTRACT FOR:</b>	Secondary Clarifier Project
<b>OWNER:</b>	City of Owosso 301 West Main Street Owosso, MI 48867
<b>CONTRACTOR:</b>	RCL Construction Co., Inc. 777 W. Maynard Road Sanford, MI 48657
<b>ENGINEER:</b>	Fishbeck 1515 Arboretum Drive, SE Grand Rapids, MI 49546
<b>ATTACHMENTS:</b>	Bulletin 1
Contractor shall indicate approval of Change Order through signing of this document and returning to Engineer. Engineer will forward to Owner, who shall indicate approval of Change Order through signing of this document and returning to Engineer. Upon receipt of fully executed (all signatures) Change Order, Engineer will distribute to all parties.	
<b>YOU ARE DIRECTED TO MAKE THE FOLLOWING CHANGES IN THE CONTRACT DOCUMENTS:</b>	
<b>ITEM NO. 1:</b>	Drying Bed Drain Line Incorporate Item No. 1 of Bulletin No. 1, change 8" PVC SDR26 drain piping for the drying beds to 18" PVC SDR26 pipe.
ADD: \$76,000 and 0 Days	

CHANGE IN CONTRACT PRICE:	CHANGE IN CONTRACT TIMES:
Original Contract Price:  <u>\$5,773,100</u>	Original Contract time: September 5, 2024 Substantial Completion: December 1, 2025 Ready for final payment: January 16, 2026
Previous Change Order No.: <u>N/A</u> <u>\$ N/A</u>	Net change from previous Change Orders: <u>0 Days</u>
Contract Price prior to this Change Order:  <u>\$5,773,100</u>	Contract Time prior to this Change Order: Substantial Completion: December 1, 2025 Ready for final payment: January 16, 2026
Net increase of this Change Order:  <u>\$76,000</u>	Net increase/decrease of this Change Order:  <u>0 Days</u>
Contract Price with all approved Change Orders:  <u>\$5,849,100</u>	Contract Time with all approved Change Orders: Substantial Completion: December 1, 2025 Ready for final payment: January 16, 2026

CHANGE ORDER  
PAGE 2 OF 2

RECOMMENDED

APPROVED

APPROVED

By:   
Engineer  
Brian Van Zee,  
Sr. Water and Wastewater  
Engineer  
Name and Title of Signatory

By: \_\_\_\_\_  
Contractor  
Nick Coon,  
Project Manager  
Name and Title of Signatory

By: \_\_\_\_\_  
Owner  
Ryan Suchanek,  
Director of Public Services &  
Utilities  
Name and Title of Signatory

Date: October 14, 2024

Date: October 14, 2024

Date: \_\_\_\_\_

END OF CHANGE ORDER

BULLETIN  
PAGE 1 OF 2

CONTRACT FOR:	City of Owosso Wastewater Treatment Plant
OWNER:	City of Owosso 301 West Main Street Owosso, MI 48867
CONTRACTOR:	RCL Construction Co., Inc. 777 W. Maynard Road Sanford, MI 48657
ENGINEER:	Fishbeck 1515 Arboretum Drive, SE Grand Rapids, MI 49546
DRAWING REVISION NO.:	B1
ISSUED HEREWITH:	
SPECIFICATION SECTIONS:	
SHEETS:	D101, C201, C401, C402

The items below are being considered as possible changes to the Contract Documents for this Project. Contractor is requested to submit changes in cost, if any, for each item and indicate whether it is an addition to or deduction from the Contract Price. Costs are requested as lump sums unless otherwise noted as a unit cost. Include all labor, materials, overhead and profit, trades, subcontractors, and related costs. After reviewing the effects of those changes in the Work, Owner may issue a Change Order specifying which changes are to be incorporated in the Work, if any.

This Bulletin is not a Change Order and is not to be deemed authorization to proceed with the changes listed.

Additional work or materials, where proposed, shall meet the requirements of the Contract Documents, except where noted.

Contractor is responsible for notifying Engineer, in writing, concerning any revision or clarification which causes a change in the Contract Documents, but not specifically mentioned as a cost item in this Bulletin.

Return one completed and signed copy of the Bulletin to Engineer on or before the due date noted above.

Each proposed change has been described briefly with additional information provided concerning detailed changes required for the major trades concerned. Only one total cost figure has been requested for each item on the Bulletin; however, a complete breakdown is required for each item as supporting documentation. This will allow Owner to more easily evaluate the proposed cost changes. Each Bulletin item is an all-inclusive item and may concern work from several trades or Subcontractors. It is Contractor's responsibility to ensure that all work for each item has been included in the total cost figure provided to Owner.

**ITEM NO. 1:** Drying Bed Drain Line  
Sheet: D101 – Site Demolition Plan (reissued)  
C201 – Layout Plan (reissued)  
C401 – Utility Plan (reissued)  
C402 – Utility Profiles (reissued)

- A. Revise fence and asphalt demolition and restoration limits on north end of site along Drying Bed Drain Line.
- B. Upsize Drying Bed Drain Line to be 18" PVC SDR26 pipe. Revise routing for drain line and add Sanitary Manhole-202. Revise slopes and downstream tie-in elevation of drain line.

18" PVC SDR26 pipe ~~ADD~~ DEDUCT: \$76,000.00

OR

12" PVC SDR26 pipe ~~ADD~~ DEDUCT: \$36,300.00

BULLETIN  
PAGE 2 OF 2

RCL Construction Co., Inc.

**Nicholas Coon**  Digitally signed by Nicholas Coon  
Date: 2024.09.19 15:02:47-04'00'

---

Signature

Nicholas Coon , Project Manager

---

Name and Title of Signatory

9/19/2024

---

Date

END OF BULLETIN

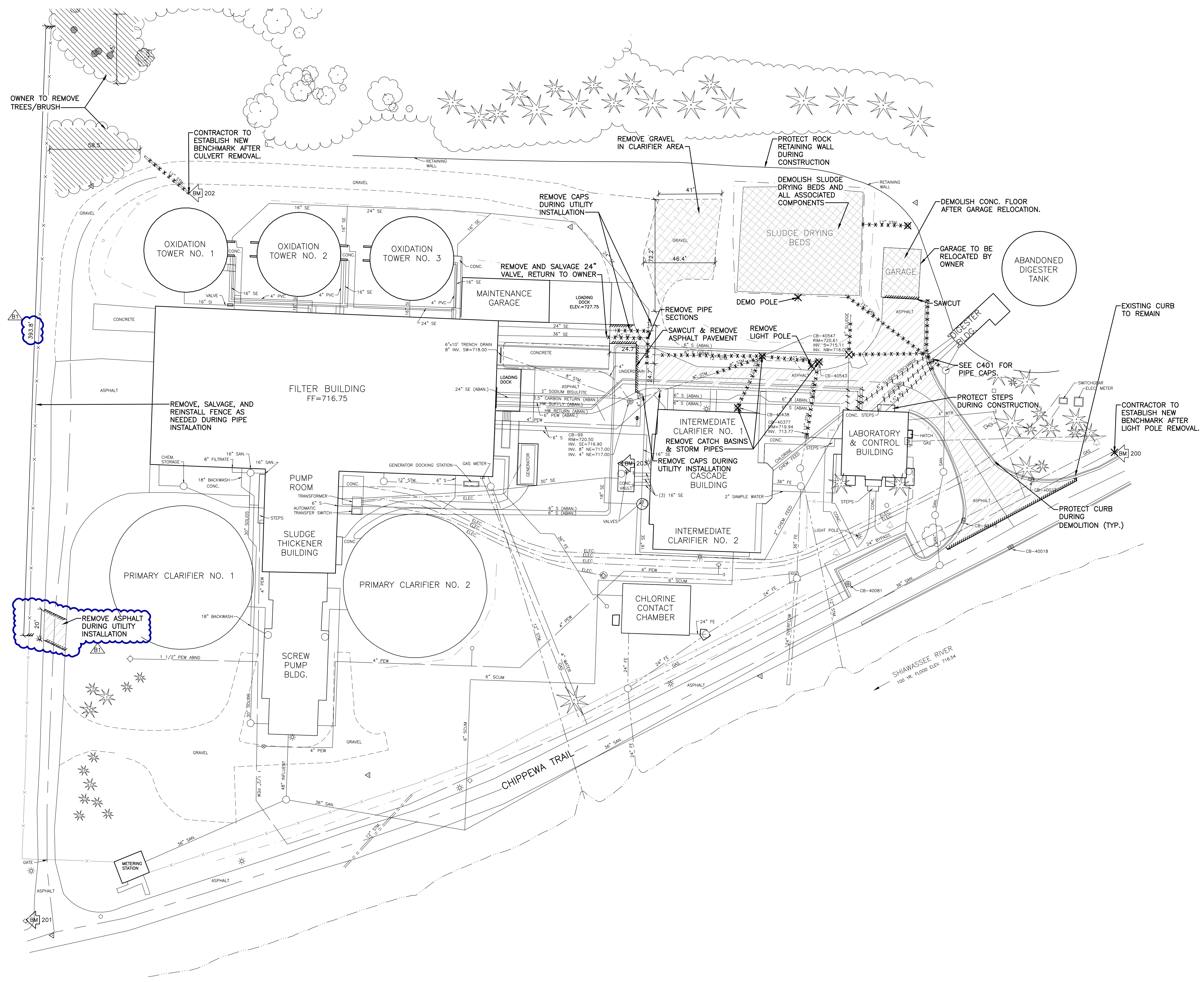

- BENCH MARKS**
- BENCH MARK 200** ELEVATION: 718.71  
MAG NAIL ON WEST SIDE OF CONCRETE LIGHT POLE BASE EAST OF CHIPPEWA TRAIL, 80'± SOUTHWEST OF CENTERLINE OF SOUTH ENTRANCE DRIVE TO SITE
  - BENCH MARK 201** ELEVATION: 716.43  
CHISELED X ON EAST-SOUTHWEST FLANGE BOLT OF HYDRANT AT NORTHEAST CORNER OF INTERSECTION OF NORTH ENTRANCE DRIVE TO SITE & CHIPPEWA TRAIL
  - BENCH MARK 202** ELEVATION: 722.98  
CHISELED X ON TOP OF WEST END OF 12" RCP CULVERT NEAR NORTHEAST CORNER OF SITE, 10'± WEST OF GRAVEL DRIVE
  - BENCH MARK 203** ELEVATION: 721.40  
MAG NAIL IN NORTHEAST CORNER OF CONCRETE PAD NORTH OF FLOCCULATION AND SETTLING TANK AREA AND 80'± SOUTH OF THE SOUTHWEST CORNER OF MAIN BUILDING

- SYMBOL LEGEND**
- LIMITS OF DISTURBANCE
  - SAWCUT
  - CURB REMOVAL
  - ABANDON PIPE WITH FLOWABLE FILL
  - PIPE REMOVAL
  - REMOVE OBJECT
  - REMOVE BUILDING
  - REMOVE BITUMINOUS PAVEMENT FULL DEPTH
  - REMOVE CONCRETE PAVEMENT
  - REMOVE GRAVEL
  - TREE PROTECTION
  - TREE REMOVAL

- NOTES**
- FIELD VERIFY THE EXTENT OF REMOVALS AND DEMOLITION PRIOR TO CONSTRUCTION. NOTIFY ENGINEER OF ANY DEVIATIONS FROM INFORMATION SHOWN.
  - PRIOR TO CONSTRUCTION ALL FENCING, BARRICADES, ENCLOSURES, ETC., MUST BE INSTALLED AND APPROVED BY OWNER OR CONSTRUCTION MANAGER.
  - DISPOSE OF DEMOLITION AND EXCAVATION MATERIALS IN ACCORDANCE WITH CONTRACT DOCUMENTS.
  - SOIL EROSION AND SEDIMENTATION CONTROL MEASURES MUST BE IN PLACE PRIOR TO STARTING REMOVALS AND DEMOLITION.
  - UNLESS SPECIFICALLY NOTED FOR REMOVAL ON THE PLANS, PROTECT ALL SIDEWALKS, DRIVES, CULVERTS, DRAINAGE STRUCTURES, AND ABOVE AS WELL AS BELOW GRADE UTILITIES. REMOVE AND REPLACE ALL SUCH ITEMS DAMAGED OR DESTROYED DURING CONSTRUCTION WITH NEW AT NO ADDITIONAL COST TO THE OWNER.
  - PROTECT EXISTING TREES TO REMAIN WITH TEMPORARY FENCING AT THE DRIP LINE. NO GROUND DISTURBANCE OR STORAGE OF MATERIAL/EQUIPMENT SHALL OCCUR WITHIN THE DRIP LINE LIMITS.
  - COORDINATE REMOVAL OR REPLACEMENT OF ELECTRICAL, TELEPHONE, CABLE TV, WATER, FIBER OPTIC CABLE AND/OR GAS LINES WITH THE AFFECTED UTILITY COMPANY. PROVIDE ADEQUATE TIME SHALL BE PROVIDED FOR RELOCATION AND CLOSE COORDINATION WITH THE UTILITY COMPANY AS NECESSARY TO PROVIDE A SMOOTH TRANSITION IN UTILITY SERVICE. PAY CLOSE ATTENTION TO EXISTING UTILITIES WITHIN THE CONSTRUCTION LIMITS. GIVE NOTICE TO ALL UTILITY COMPANIES REGARDING DESTRUCTION AND REMOVAL OF ALL SERVICE LINES AND CAP ALL LINES BEFORE PROCEEDING WITH THE WORK.
  - PERFORM CLEARING, GRUBBING, TREE AND STUMP REMOVAL, TOPSOIL REMOVAL AND STOCKPILING IN ACCORDANCE WITH THE CONTRACT DOCUMENTS.
  - BEFORE REMOVING OR ABANDONING ANY UTILITY PIPES, VERIFY NEW UTILITY PIPE HAS BEEN INSTALLED, TESTED AND IS OPERATIONAL.
  - THE LOCATIONS OF ALL EXISTING UTILITIES SHOWN ON THIS DRAWING HAVE BEEN DETERMINED FROM THE BEST INFORMATION AVAILABLE AND ARE GIVEN FOR THE CONVENIENCE OF THE CONTRACTOR. VERIFY CRITICAL INVERT INFORMATION PRIOR TO BEGINNING CONSTRUCTION.
  - SAWCUT AND REPLACE DAMAGE CAUSED TO SURROUNDING AREA PAVEMENT OUTSIDE THE CONSTRUCTION LIMITS AT NO ADDITIONAL COST TO THE OWNER.
  - COORDINATE SEQUENCING AND PHASING OF DEMOLITION WITH CONSTRUCTION MANAGER.
  - SEE OTHER DRAWINGS FOR ADDITIONAL SITE DEMOLITION WORK.
  - SAWCUT CURB AND GUTTER AND SIDEWALKS TO NEAREST JOINT.

**City of Owosso**  
Shiawassee County, Michigan  
Secondary Clarifier

**REVISIONS**

8/15/2024	B1	BULLETIN NO. 1
-----------	----	----------------

8/15/2024 | FOR CONSTRUCTION

Drawn By: BEV  
Designer: BEV  
Reviewer: BAM  
Manager: BWV

Hard copy is intended to be 24"x36" when plotted. Scale(s) indicated and graphic quality may not be accurate for any other size.

PROJECT NO.  
**231949**





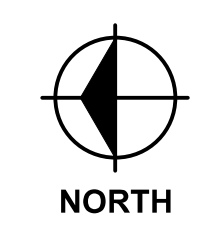

SHEET NO.

**D101**

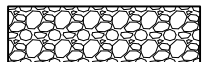
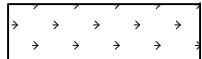
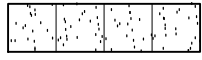
**CIVIL**  
**SITE DEMOLITION PLAN**  
SCALE: 1" = 30'  
0 15 30 60

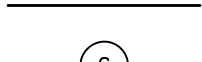

**SYMBOL LEGEND**

-  HEAVY DUTY ASPHALT PAVEMENT  
FULL DEPTH - 5"
-  1" x 1 1/2" WASHED  
CRUSHED LIMESTONE
-  4" TOPSOIL, MULCH  
BLANKET, AND SEED.
-  4" THICK CONCRETE SIDEWALK
-  EXPANSION JOINT
-  STANDARD CURB AND GUTTER
-  STANDARD INVERTED CURB AND GUTTER
-  PARKING SPACE COUNT
-  SITE LIGHT POLE
-  ALTERNATE SCOPE OF WORK

**NOTES**

1. DIMENSIONS ARE TO BACK OF CURB, OUTSIDE FACE OF BUILDING, AND EDGE OF PAVEMENT UNLESS NOTED OTHERWISE.
2. KEEP THE APPROVED AND/OR MOST CURRENT SET OF PROJECT DRAWINGS ON SITE AT ALL TIMES. CONTRACTOR TO CONFIRM THEY ARE IN POSSESSION OF THE MOST CURRENT DRAWING FILES.
3. RESTORE ALL DISTURBED LAWN AREAS WITH 4" TOPSOIL, MULCH BLANKET, AND SEED.

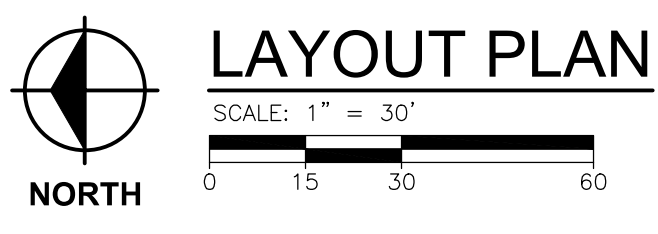
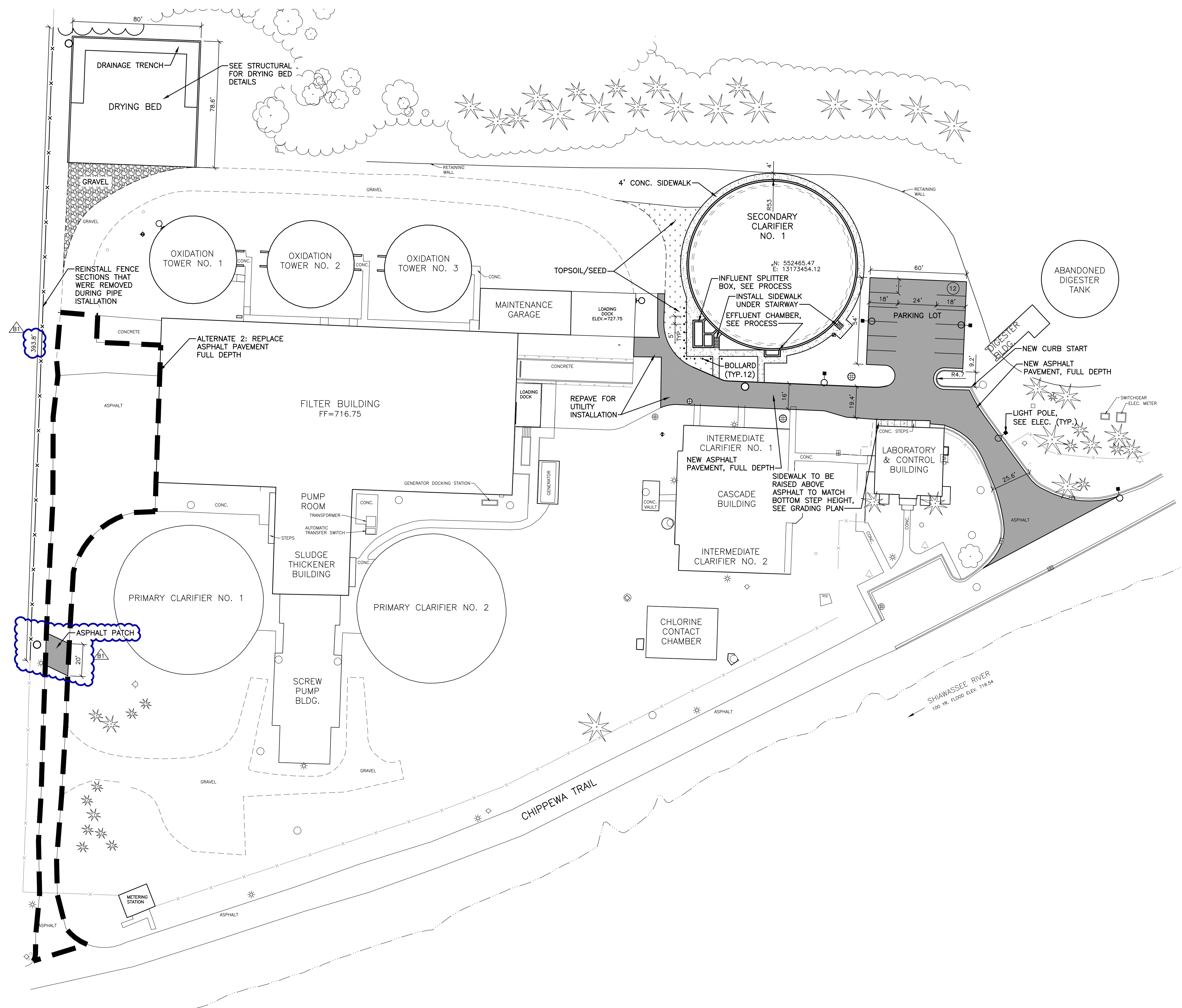

PLOT INFO: Z:\02\03\2019\04\CADD\C201\_231949.DWG LAYOUT: C201 DATE: 9/5/2024 TIME: 10:52:19 AM USER: RIVENNE

**REVISIONS**

9/5/2024	B1	BULLETIN NO. 1
----------	----	----------------

**FOR CONSTRUCTION**

Drawn By	BEV
Designer	BEV
Reviewer	BAM
Manager	BWV

Hard copy is intended to be 24"x36" when plotted. Scale(s) indicated and graphic quality may not be accurate for any other size.

PROJECT NO.  
**231949**

SHEET NO.

**C201**

**City of Owosso**  
Shiawassee County, Michigan  
Secondary Clarifier

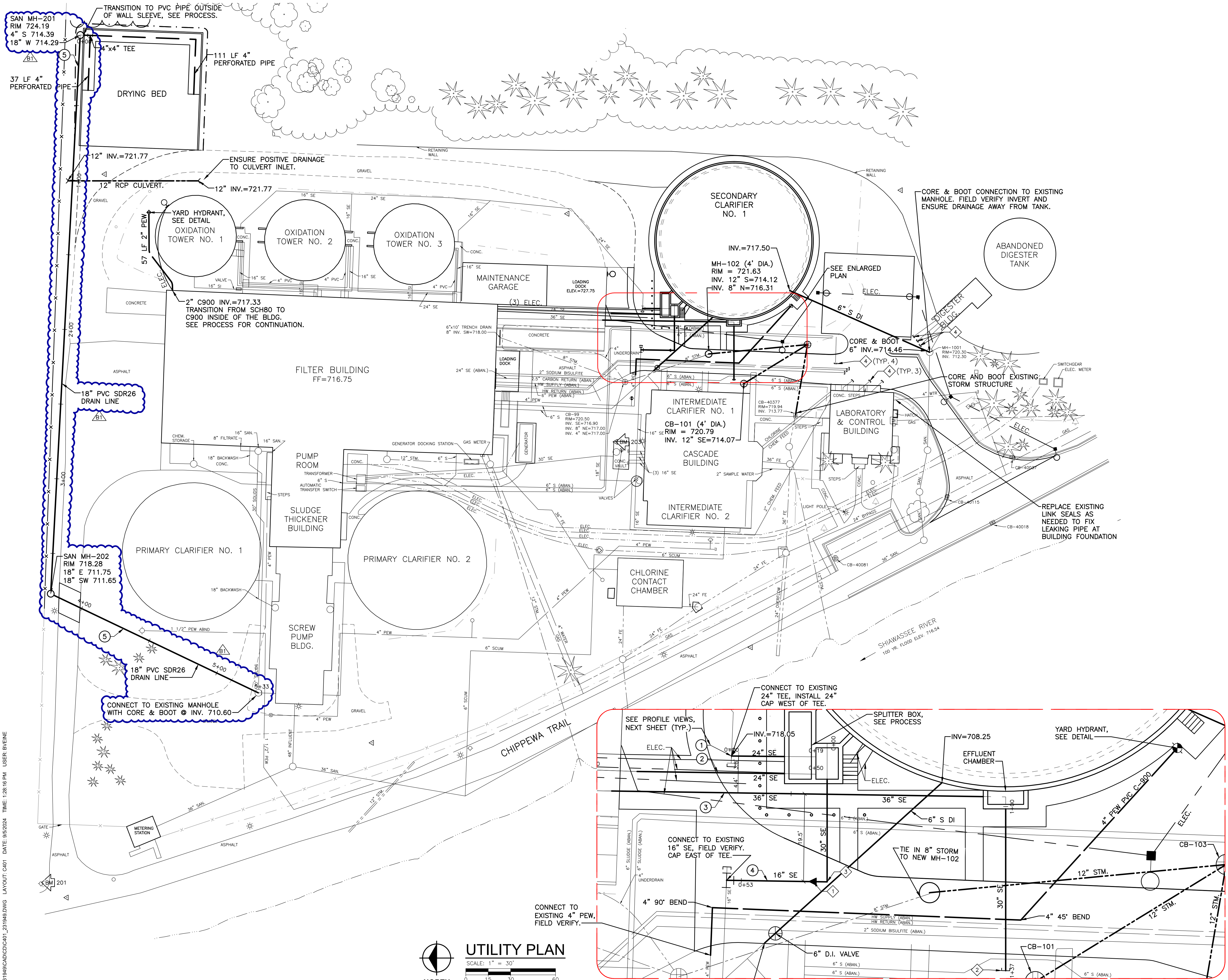

- BENCH MARKS**
- BENCH MARK 200 ELEVATION: 718.71  
MAG NAIL ON WEST SIDE OF CONCRETE LIGHT POLE BASE EAST OF CHIPPEWA TRAIL, 80'± SOUTHEAST OF CENTERLINE OF SOUTH ENTRANCE DRIVE TO SITE
  - BENCH MARK 201 ELEVATION: 716.43  
CHISELED X ON EAST-SOUTHEAST FLANGE BOLT OF HYDRANT AT NORTHEAST CORNER OF INTERSECTION OF NORTH ENTRANCE DRIVE TO SITE & CHIPPEWA TRAIL
  - BENCH MARK 202 ELEVATION: 722.98  
CHISELED X ON TOP OF WEST END OF 12" RCP CULVERT NEAR NORTHEAST CORNER OF SITE, 10'± WEST OF GRAVEL DRIVE
  - BENCH MARK 203 ELEVATION: 721.40  
MAG NAIL IN NORTHEAST CORNER OF CONCRETE PAD NORTH OF FLOCCULATION AND SETTLING TANK AREA AND 80'± SOUTH OF THE SOUTHWEST CORNER OF MAIN BUILDING

- SYMBOL LEGEND**
- 8" SAN. SANITARY SEWER & MANHOLE
  - 30" SE SECONDARY EFFLUENT
  - 8" SI SECONDARY INFLUENT
  - 36" FE FINAL EFFLUENT
  - 6" S SLUDGE
  - WYE & LEAD
  - RISER & LEAD
  - STANDARD SEWER CLEANOUT
  - 12" STORM STORM SEWER & MANHOLE
  - CATCH BASIN
  - UNDERDRAIN
  - 8" WATER WATER MAIN
  - 6" PEW PROCESS EFFLUENT WATER
  - VALVE & BOX
  - VALVE & CHAMBER
  - METER
  - PLUG
  - STANDARD FIRE HYDRANT ASSEMBLY
  - CURB STOP & BOX
  - GAS MAIN
  - ELECTRIC
  - TELEPHONE/FIBER OPTIC

- NOTES**
- EXISTING UTILITIES LOCATIONS SHOWN ARE APPROXIMATE. FIELD VERIFY UTILITY LOCATION, CROSSINGS AND TIE IN POINTS BEFORE INSTALLATION.
  - VERIFY THE HORIZONTAL AND VERTICAL LOCATION OF EXISTING UTILITIES PRIOR TO EXCAVATION WHERE NECESSARY.
  - PROTECT AND MAINTAIN SERVICE OF OTHER UTILITIES AT CROSSINGS.
  - DO NOT CONNECT ROOF DRAINS, FOUNDATION DRAINS, AND OTHER CLEAN WATER SERVICES TO THE SANITARY SEWER.
  - END SECTIONS ARE INCLUDED IN PIPE LENGTHS SHOWN.
  - PROVIDE RIPRAP AT ALL END SECTIONS UNLESS OTHERWISE NOTED.
  - PROVIDE AND MAINTAIN INLET FILTERS AT ALL CATCH BASIN INLETS, DURING CONSTRUCTION.
  - WATERLINES TO HAVE A MINIMUM OF 5.5 FEET OF COVER.
  - PROVIDE A MINIMUM OF EIGHTEEN (18) INCHES OF VERTICAL SEPARATION AND TEN (10) FEET OF HORIZONTAL SEPARATION BETWEEN THE WATER MAIN AND ALL SANITARY AND STORM SEWERS.
  - ADJUST ALL CASTINGS TO FINISH GRADES.
  - PIPE LENGTHS ARE TO CENTER OF STRUCTURES UNLESS NOTED OTHERWISE. ALL PIPE LENGTHS ARE FOR THE CONVENIENCE OF THE CONTRACTOR.
  - ALL PIPE SIZES ARE INTERIOR DIAMETER.

- KEY NOTES**
- 30"x16" D.I. REDUCER
  - 30" D.I. CAP
  - 30" 90° D.I. BEND
  - CAP UTILITIES

**REVISIONS**

05/2024	B1	BULLETIN NO. 1
---------	----	----------------

**FOR CONSTRUCTION**

Drawn By	AWH
Designer	BEV
Reviewer	BAM
Manager	BWV

Hard copy is intended to be 24"x36" when plotted. Scale(s) indicated and graphic quality may not be accurate for any other size.

PROJECT NO.  
**231949**

SHEET NO.

**C401**



REVISIONS	
8/5/2024	B1 BULLETIN NO. 1

8/15/2024 FOR CONSTRUCTION

Drawn By AWH  
Designer BEV  
Reviewer BAM  
Manager BWV

Hard copy is intended to be 24"x36" when plotted. Scale(s) indicated and graphic quality may not be accurate for any other size.

PROJECT NO.  
231949

SHEET NO.

**C402**

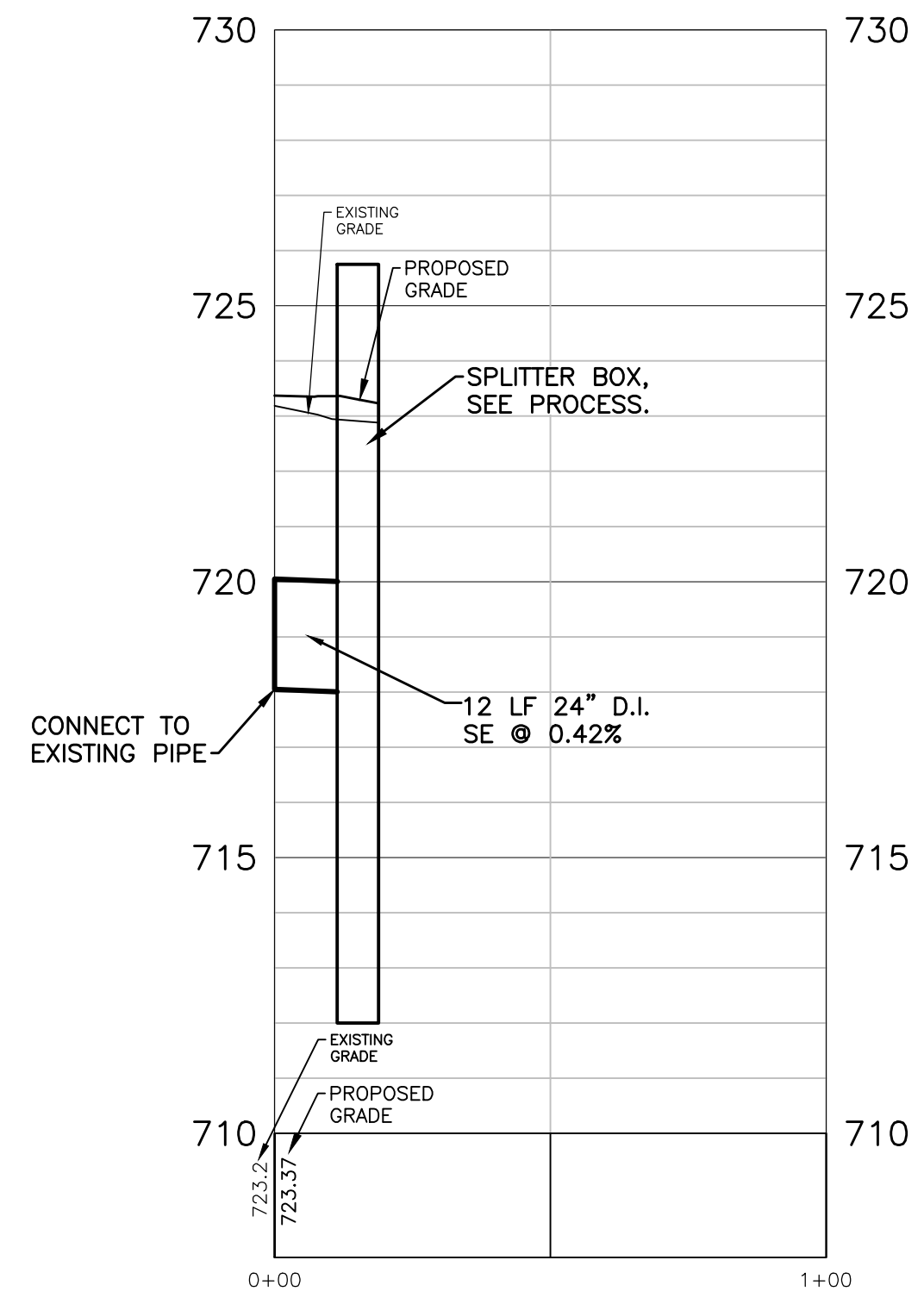

① **24" SECONDARY TOWER EFFLUENT**  
SCALE: 1" = 30"  
VERT SCALE: 1" = 3'

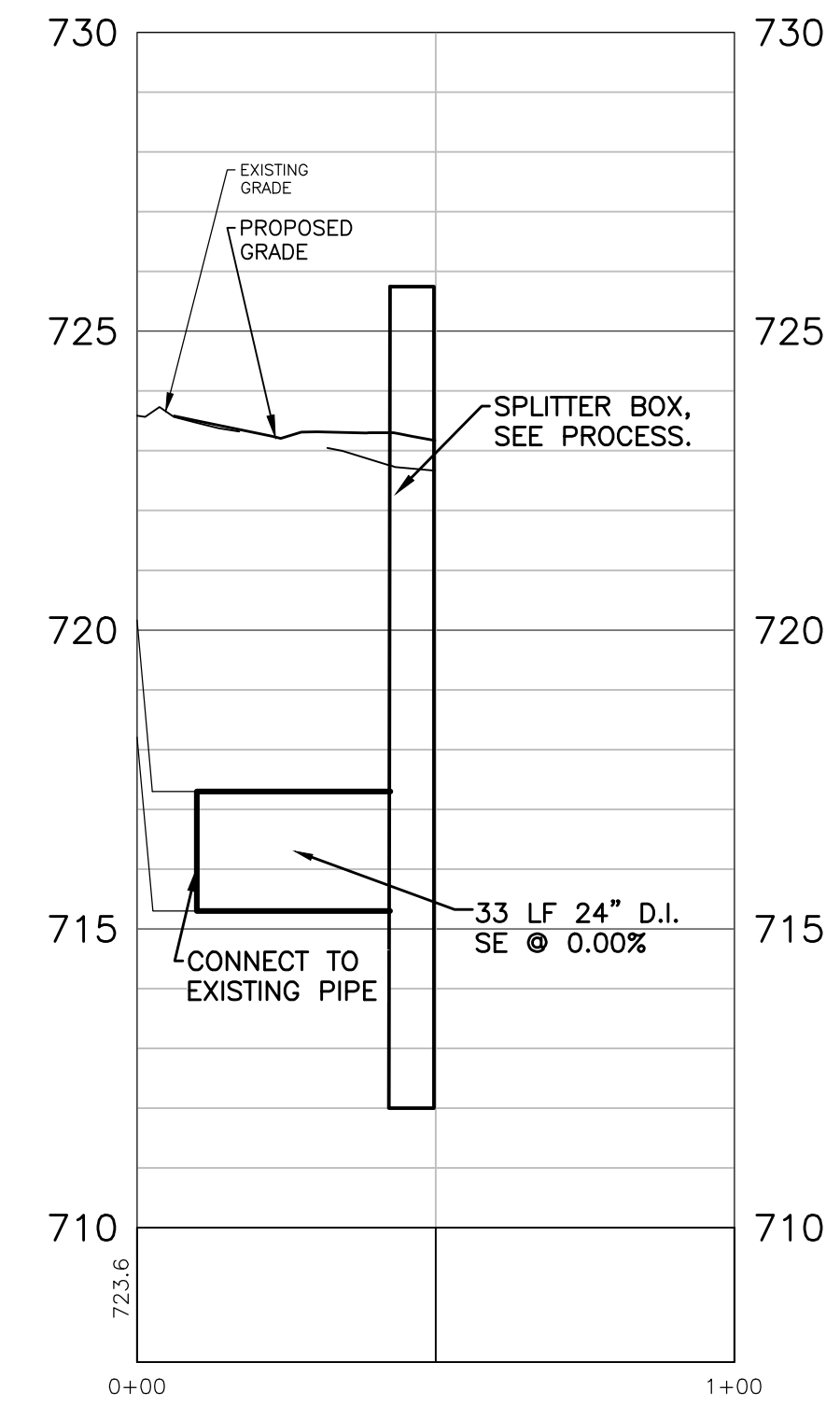

② **24" SECONDARY EFFLUENT**  
SCALE: 1" = 30"  
VERT SCALE: 1" = 3'

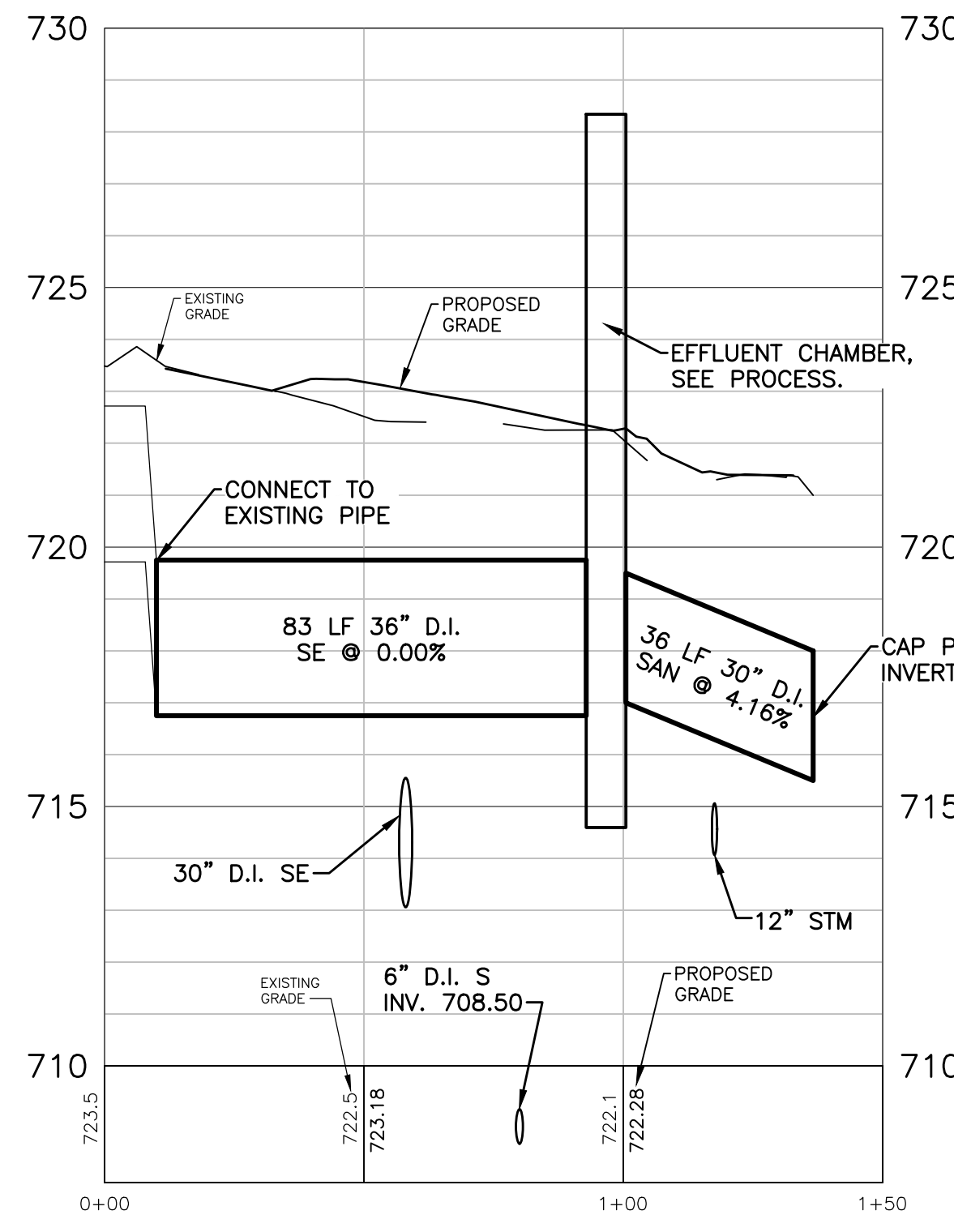

③ **36" SECONDARY EFFLUENT**  
SCALE: 1" = 30"  
VERT SCALE: 1" = 3'

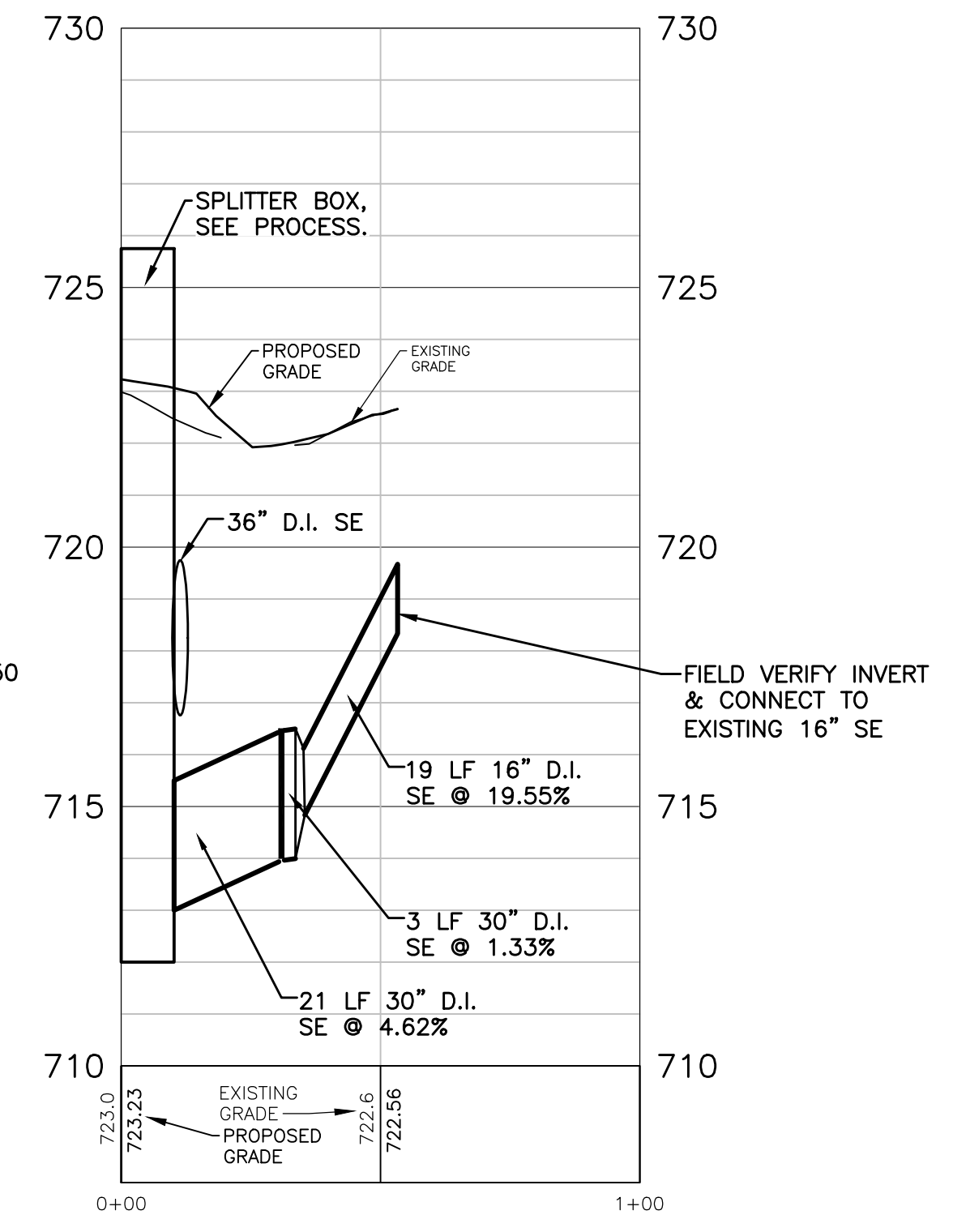

④ **30" SECONDARY TOWER EFFLUENT**  
SCALE: 1" = 30"  
VERT SCALE: 1" = 3'

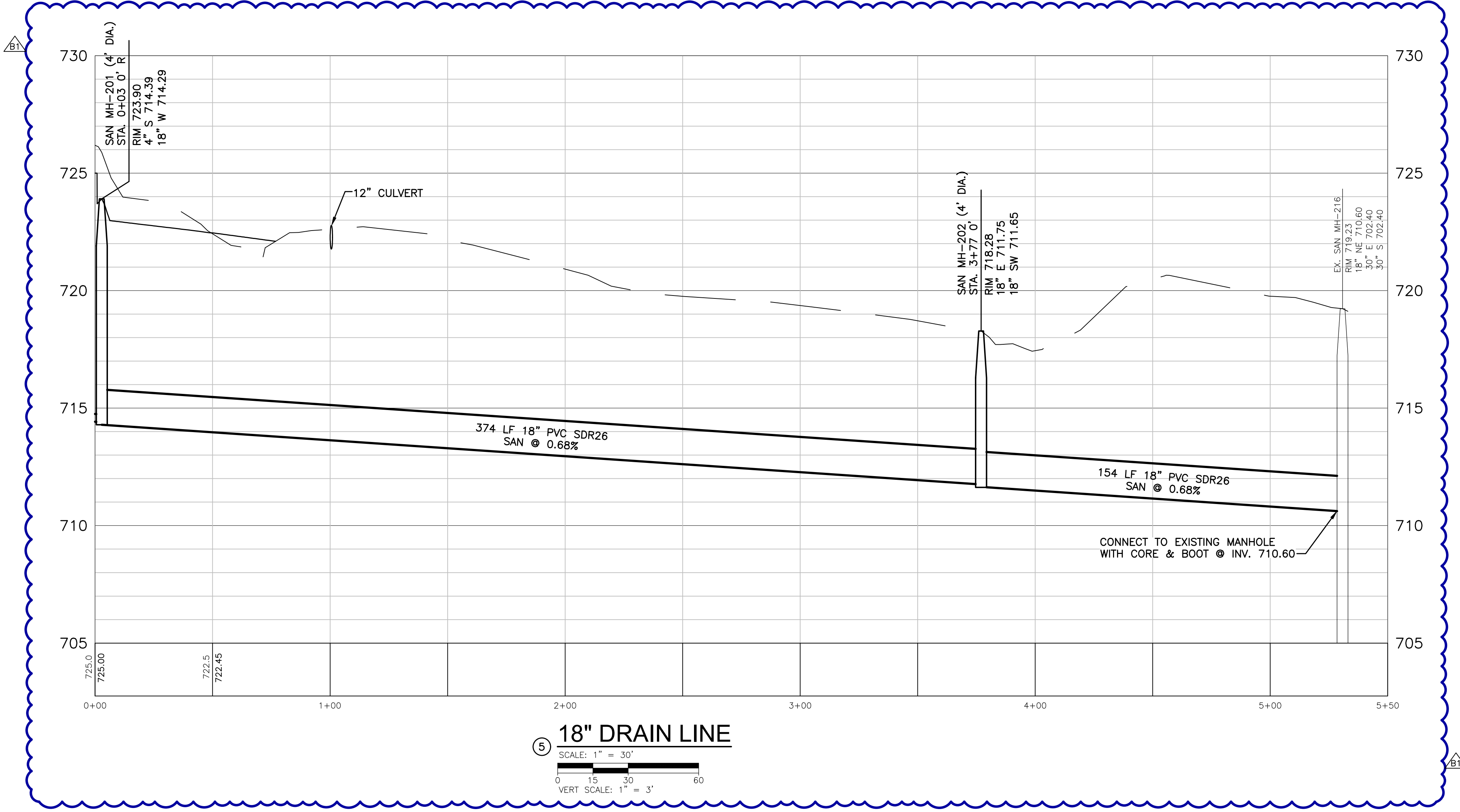

⑤ **18" DRAIN LINE**  
SCALE: 1" = 30"  
VERT SCALE: 1" = 3'



## MEMORANDUM

---

301 W. MAIN ▪ OWOSSO, MICHIGAN 48867-2958 ▪ WWW.CI.OWOSSO.MI.US

---

**DATE:** November 4, 2024

**TO:** Mayor Teich and the Owosso City Council

**FROM:** Ryan E. Suchanek, Director of Public Services & Utilities

**SUBJECT:** Palmer 3A and Juniper 1 Well Houses Project Change Order #5

### RECOMMENDATION:

Approval of increased payment for construction work by Sorensen Gross Company (Flint, MI) for the Palmer 3A and Juniper 1 Well Houses project in the amount of \$3,202.00.

### BACKGROUND:

On January 17, 2023, the City received bids for the Palmer 3a and Juniper 1 Well Houses Project. Work includes construction of two (2) well houses, two (2) vertical line-shaft turbine pumps, water mains to connect water wells to existing raw water mains for the following wells:

- Palmer 3A
- Juniper 1

On February 6, 2023, City Council approved a resolution to tentatively award the Palmer 3A and Juniper 1 Well Houses Project contract to Sorensen Gross Company. As Sorensen Gross Company was the confirmed low and most responsive bid and agreed to perform the work for a total cost amount of \$2,363,238.00.

On August 21, 2023, City Council approved change order #1, for \$8,029.00 due to a location error by Engineering firm OHM, which caused the need for additional materials and labor which weren't initially planned for.

On December 4, 2023, City Council approved change order #2, for \$7,904.00, due to the discovery that unsuitable soils were present at the proposed location for the Palmer 3A well house, the contractor was required to remove the unsuitable soils and replace them with sound, compacted materials. Change order #2 covered the additional work and materials that were required. OHM reviewed the proposed change order and cost, and found it to be fair and acceptable. EGLE determined change order #2 was within the scope of the approved loan project.

On March 4, 2024, City Council approved change order #3 for \$3,202.00, due to the discovery that the existing raw water main was mismarked, which meant the location instead of being in the green space, was actually just under the road. Causing a lost day of work for the contractor. The

total cost to the contractor was \$3,202.00 and a contract day for completion. EGLE has determined this change order is within the scope of the approved loan project. To the extent project contingency funds are sufficient to cover the allowable costs of the change order, state approval will result in loan participation.

On April 17, 2024 the City approved change order #4 an extension of time due to extended lead time of materials, no price change. Adding 217 days to Substantial Completion, and 217 days to Ready for Final Payment.

More recently it was discovered that a float was missing at both new well sites. The floats are required to connect these new well sites to the in process new SCADA system also being worked on by a separate contractor and engineer. This change is for both the purchase, and installation of a float at each new well house, for a total of two (2) new floats. This change increases the project cost by \$1,182.00, bringing the total project cost from \$2,382,373.00 to \$2,383,555.00. Both OHM and City Staff have reviewed the proposed change and costs, and have found it to be fair and acceptable.

**FISCAL IMPACTS:**

The project is funded by the DWSRF and ARPA Funds, with the additional costs of \$1,182.00. Final expenses in the amount of \$2,383,555.00 shall be paid from the Water Fund and 2023 SRF Bond Funds.

**Document originated by:** Ryan E. Suchanek, Director of Public Services & Utilities

ATTACHMENTS:     (1)     Resolution  
                          (2)     CE #10

Master Plan Implementation Goals: 1.5, 3.4.

**RESOLUTION NO.**

**AUTHORIZING CHANGE ORDER NO. 5  
TO THE CONTRACT BETWEEN THE CITY OF OWOSSO  
AND SORENSEN GROSS COMPANY OF FLINT, MICHIGAN  
FOR THE PALMER 3A AND JUNIPER 1 WELL HOUSES PROJECT  
FOR WATER SYSTEM IMPROVEMENTS**

WHEREAS, the City of Owosso, Shiawassee County, Michigan, approved a contract with Sorensen Gross Company, on February 6, 2023 for the construction and installation of two (2) well houses, two (2) vertical line-shaft turbine pumps, water mains to connect water wells to existing raw water mains for wells Palmer 3A and Juniper 1, are approved 2023 SRF planned project; and

WHEREAS, the project is now underway and a change order is necessary to reconcile contract work and supplies to be used.

NOW THEREFORE BE IT RESOLVED by the City Council of the City of Owosso, Shiawassee County, Michigan that:

- FIRST: The City of Owosso has heretofore determined that it is advisable, necessary and in the public interest to amend the Water System Improvement Palmer 3A and Juniper 1 Well Houses project contract with Sorensen Gross Company to increase the contract amount to update contract work and supplies to be used.
- SECOND: The Mayor and City Clerk are instructed and authorized to sign the document substantially in form attached as CE#10 (Change Order No. 5) in the amount of \$1,182.00; an increase to the Contract for Services between the City of Owosso and Sorensen Gross Company, revising the total current contract amount from \$2,382,373.00 to \$2,383,555.00.
- THIRD: The Accounts Payable department is authorized to pay Sorensen Gross Company for work satisfactorily completed up to the revised contract amount of \$2,383,555.00.
- FOURTH: The above expenses shall be paid from the Water Fund, and SRF Bond Funds



October 9, 2024

City of Owasso & OHM Advisors  
Attn: Traci Roberson & Matt Kennedy  
929 Bridgeview S  
Saginaw, MI 48604

RE: Palmer 3A and Juniper Well House Designs  
SGC Job#: 88303  
CE #10 Added M8600 Floats (2)

Dear Traci

We are pleased to quote the following work associated with SGC CE#10, dated October 9, 2024 for costs to complete all labor and material to add M8600 Polypropylene floats (2) one at each well house.

Total Amount of: \$1,182.00

Please see the attached back-up documentation for reference.

Please contact our office with any questions or if you need any additional information.

APPROVED BY: \_\_\_\_\_

DATE: \_\_\_\_\_

Sincerely,

Sorensen Gross Company

Bruce Hemingway  
Project Manager

CC: SG File

SORENSEN GROSS CONSTRUCTION

<b>JOB NAME:</b>	Palmer 3A & Juniper Wellhouse		<b>DATE:</b> 10/9/2024
<b>Description;</b>	CE #10 added M8600 Floats (2)	<b>Supervision</b>	\$75.00 per hr
<b>Job Number;</b>	88303	<b>Laborer</b>	\$52.00 per hr
		<b>Carpenter</b>	\$57.00 per hr

DESCRIPTION	QUANTITY	UNIT	UNIT COST	MATERIAL	UNIT COST	LABOR	TOTAL
No-Labor				\$0		\$0	\$0
				\$0		\$0	\$0
				\$0		\$0	\$0
				\$0		\$0	\$0
				\$0		\$0	\$0
				\$0		\$0	\$0
				\$0		\$0	\$0
				\$0		\$0	\$0
				\$0		\$0	\$0
				\$0		\$0	\$0
				\$0		\$0	\$0
				\$0		\$0	\$0
				\$0		\$0	\$0
SUBTOTAL				\$0		\$0	\$0
						6%	\$0
						15%	\$0
<b>SUBTOTAL SORENSEN GROSS WORK</b>						<b>ADD</b>	<b>\$0</b>

**SUBCONTRACT WORK**

Weinstein Electric	\$1,064
--------------------	---------

<b>SUBTOTAL SUBCONTRACT WORK</b>	<b>ADD</b>	<b>\$1,064</b>
SUBCONTRACT FEE	10.00%	\$106
		<b>\$1,170</b>
<b>SUBTOTAL</b>		
Add bonds and insurance	1%	\$12
<b>Total Lump Sum Cost</b>		<b>\$1,182</b>

# PROPOSAL REQUEST 01

DISTRIBUTION

Owner  
 Contractor

**TO:** Sorensen Gross  
 3407 Torrey Road  
 Flint, Michigan 48507

**DATE:** October 3, 2024

**PROJECT:** Palmer 3A & Juniper Wellhouse

**Attn:** Bruce Hemingway

**INTENT: This is not a change order.** This is a request to the Contractor for a detailed price breakdown (debit or credit) of proposed changes in the work. Contract unit prices are intended to be used for changes in pay item quantities. Any changes to cost other than those due to quantity changes must be clearly stated.

**PROPOSED CHANGES:**

Provide (2) Madison M8600 Polypropylene floats with 316 stainless steel stem, 1/4" NPT. Install per details shown below, one in each wellhouse. Coordinate mounting location with Owner and/or Field Engineer.

Final conduit and wiring between junction box and PLC enclosure BY OTHERS.

COIL EXTRA WIRE IN JUNCTION BOX.

CONDUIT, WIRES AND CONNECTION BETWEEN JUNCTION BOX AND PLC BY OTHERS (COUNTY LINE)

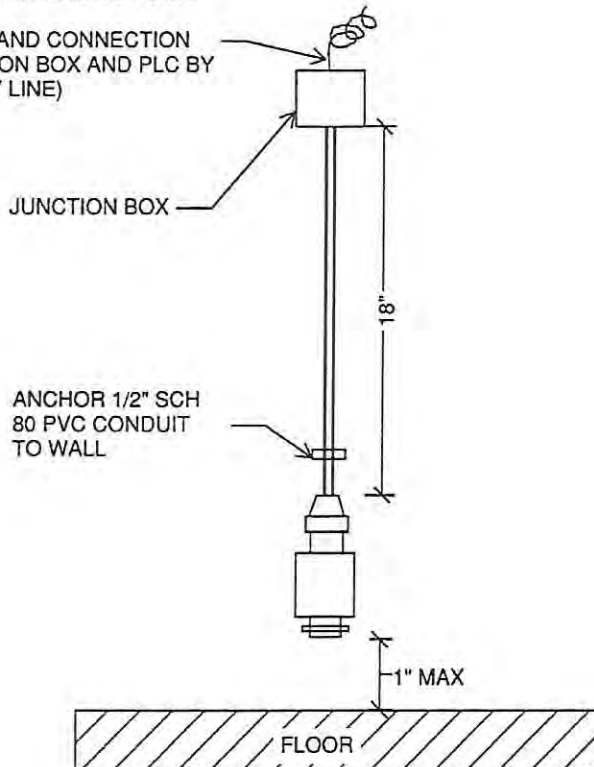

**REASON FOR CHANGE:**

Coordination between the SCADA contract and the Wellhouse contract missed the provision of the floats.

Will the work covered by this Proposal Request require an extension of the contract completion date No? How many calendar days —?

It is required that the spaces provided for the change in Contract amount, signature and date be filled in and returned to this office. A quotation, showing the Proposal Request number and detailed cost setting forth the breakdown of labor, material and markup, is to be attached to each copy of the Proposal Request, showing the addition, credit or no charge for this item.

OHM Advisors

*Matthew M. Kennedy*  
BY Matt Kennedy

Proposed Change in Contract Amount:

ONE THOUSAND SIXTY FOUR <sup>00</sup>/<sub>100</sub> Dollars  
(\$1,064.00).

BY *[Signature]*  
DATE 09 Oct 24





301 W. MAIN, OWOSSO, MICHIGAN 48867 · (989) 725-0599

DATE: October 29, 2024  
TO: Mayor Teich and City Council  
FROM: Tanya Buckelew, Planning & Building Director  
SUBJECT: Fee Schedule Review

**RECOMMENDATION:**

Staff recommends the annual review and amendments to the City of Owosso 2024 Fee Schedule to be effective November 4, 2024.

**BACKGROUND:**

Before the start of the new fiscal year, no changes were proposed and therefore the fee schedule was not presented to council for review.

An RRC requirement is that regardless of changes, the fee schedule should be reviewed by City Council on an annual basis.

The only proposed change is removing line items pertaining to the Gould House (page 7 under Historical Commission).

**FISCAL IMPACT:**

None

Master Plan Implementation Goals: A-7.

**RESOLUTION NO.**

**UPDATING THE SCHEDULE FOR FEES, LICENSES, FINES AND CHARGES  
FOR THE CITY OF OWOSSO**

WHEREAS, the *City of Owosso Code of Ordinances* provides for the establishment of many fees, licenses, fines and charges to be established by resolution; and

WHEREAS, on August 5, 2013 the City Council adopted Resolution No. 90-2013 creating a schedule of fees, licenses, fines and charges; and

WHEREAS, said schedule must be annually reexamined and updated; and

WHEREAS, the City Council has reviewed the charges and determined that the November 4, 2024 fees, licenses, fines and charges shall be in accordance with this resolution and the attached schedule.

NOW THEREFORE BE IT RESOLVED by the City Council of the City of Owosso, Shiawassee County, Michigan that:

- FIRST: the attached schedule for fees, licenses, fines and charges is hereby adopted effective November 4, 2024.
- SECOND: any parts of resolutions and memoranda in conflict with this resolution are hereby repealed.
- THIRD: this resolution is intended to preserve all existing charges and fees set forth in any resolution, ordinance, or law which are not in conflict with this resolution and attached schedule and to fulfill the requirements of any ordinance authorizing the City Council to establish fees by resolution.
- FOURTH: fees for public records not set forth in this resolution and attached schedule, or in any other resolution, ordinance, or law, shall be set by the City manager in accordance with Act 442 of the Public Acts of 1976, as amended.
- FIFTH: Fees for public services not specifically set forth in this resolution and the attached schedule or in any other resolution, ordinance, or law may be established by the City manager, who shall promptly notify the City Council in writing of each of them. The City manager shall establish fees for public services based upon the cost of providing the public service.

**CITY OF OWOSSO  
2024 FEE SCHEDULE  
Effective November 4, 2024**

<b>1. ASSESSING</b>	
• Application fee for IFEC extension	\$550
Application fee for IFT tax abatement – Not to exceed limits of Statute MCL 207.555(3) in which the lesser of the actual cost of processing the application or 2% of total property taxes abated during the term that the exemption certificate is in effect can be charged	
➢ Establishing	\$1,500
➢ Exemption certificate	\$1,500
• Application fee for industrial development district	\$1,500
• Application fee for industrial facilities	
➢ Exemption certificate	\$1,500
➢ Exemption certificate transfer	\$500
• Application fee for project cost revision	\$500
• Application fee for project extension	\$500
• Application fee for tax abatement projects	\$800
<b>2. BUILDING DEPARTMENT</b>	
<i>Income limit - fee waiver – Building permits and inspections will be required. However, permit fees will be waived for owner occupied residential buildings for households that have annual incomes less than 30% of the Michigan State Housing Development Authority (MSHDA) area Minimum Income (AMI). The waiver will cover permits for bringing a structure into code compliance and for replacement of roofs, windows, and siding. To qualify, the applicant must submit Michigan or Federal 1040 tax returns for the last three years along with any other financial and ownership information required for determination.</i>	
• Accessory structure-zoning compliance-200 sq. ft. and under	\$75
• Accessory structure-zoning compliance-over 200 sq. ft.	same as building permit fees
• Base fee (non-refundable)	\$40
• Adult entertainment license fee	\$1,500
Note: If application denied, ½ fee returned	
• Adult entertainment license fee renewal	\$1,500
Note: a late penalty of \$100 if renewal filed less than 60 days before license exp. If application denied, ½ of total fees collected returned.	
• License renewal	
➢ Late fee first 15 days	License fee + 25%
➢ Late fee beyond 15 days	License fee + 50% adult entertainment penalties
➢ Adult entertainment penalties	\$500
• Building board of appeals application fee	\$200
• Building permit	
➢ Up to \$1,000-includes base fee and 1 inspection	\$110
➢ \$1,001 to \$2,000-includes base fee and 1 inspection	\$150
ADD \$40 base fee and \$80 per inspection to the following:	
➢ \$2,001 to \$50,000	\$65 + \$10 per \$1,000 over \$2,000
➢ \$50,001 to \$500,000	\$545 + \$10 per \$1,000 over \$50,000
➢ \$500,001 and above	\$5,000 + \$6 per \$1,000 over \$500,000
• Businesses-NEW-(existing building)	\$75
• Demolition-Commercial-based on size of building	\$185 + \$1 per sq. ft. over 2,000 sq. ft.
• Demolition-Garage-includes base fee and 1 inspection	\$115
• Demolition-House-includes base fee and 1 inspection	\$185
• Fence-zoning-residential	\$85
• Fence-commercial	same as building permit fees

• Home occupation-type B home permit	\$55
• Inspections-each	\$80
• License/registration fee	\$0
• Marihuana fees	
➢ Medical Marihuana Facilities (at time of application and annual renewal)	\$5,000
➢ Adult Use Recreational Establishments (at time of application and annual renewal)	\$5,000
➢ Marihuana Transfer Fee	\$5,000
• Mobile/Modular Home	\$250
• Moving building	\$200
• Penalty for work prior to obtaining permit	cost of permit + \$180
• Plan review	55% of permit fee
• Plan review-plans are returned to application for modifications	\$55 + \$60/hour
• Roofing permit-residential	
➢ Up to \$5,000 (includes base fee and 1 inspection)	\$90
➢ \$5,001 to \$10,000 (includes base fee and 1 inspection)	\$120
➢ Over \$10,000	same as building permit fees
• Roofing permit-commercial	same as building permit fees
• Siding	\$90
• Sign	\$0.60/sq. foot
➢ Temporary sign (60 days)	\$75
• Swimming pools permit-above ground (zoning compliance)	\$75
• Swimming pool permit-in ground	same as building permit fees
• Tank removal	\$100
• Vacant property registration	\$150
• Wheel chair ramp/door modification (residential-permit and inspections required)	no fee
• Windows-residential	\$90
• Windows-commercial	same as building permit fees
<b>3. ELECTRICAL</b>	
• Base fee (non-refundable)	\$40
• Branch circuits	\$20
• Feeders-bus duct (per 50 ft. or fraction thereof)	\$20
• Electric baseboard heater	\$20
• Fire alarm system	\$155
➢ Fire alarm system-each additional pull station	\$20
• Furnace-unit heater	\$20
• Garage	\$55
• Generator-residential	\$30
• Generator-commercial	\$55
• Inspections-each (including Safety inspections)	\$80
• License/registration fee	\$0
• Low voltage/data/telecom outlets	
➢ 1-19 devices, each	\$10
➢ 20-300 devices	\$100
➢ Over 300 devices	\$300
• Mobile/modular home	\$150
• Motors	
➢ Up to 20 KVA or HP, 1-25 units (each)	\$20
➢ Up to 20 KVA or HP (each additional unit after 25)	\$10
➢ Over 20 KVA or HP, 1-25 units (each)	\$20

➤ Over 20 KVA or HP (each additional unit after 25)	\$12
• Outlets/receptacles/fixtures/other (per 25 or fraction thereof)	\$20
• Penalty for work prior to obtaining permit	cost of permit + \$180
• Plan review	\$100/hr. (minimum 1 hour)
• Power outlets (a/c/range/dryer/dishwasher/disposal) each	\$20
• Service	
➤ 0-200 amps	\$30
➤ 201-600 amps	\$35
➤ 601-800 amps	\$40
➤ 801-1200 amps	\$45
➤ Over 1200 amps	\$50
• Sub-panels	
➤ 0-200 amps	\$30
➤ 201-600 amps	\$35
➤ 601-800 amps	\$40
➤ 801-1200 amps	\$45
➤ Over 1200 amps	\$50
• Signs	\$80
• Whole house permit	\$150
<b>4. MECHANICAL-COMMERCIAL/INDUSTRIAL</b>	
• Base fee (non-refundable)	\$40
• Air conditioning and refrigeration	
➤ Absorption units/chiller	\$95
➤ Centrifugal units/chiller	\$95
➤ Compressor – ½ - 15 HP	\$40
➤ Compressor-15 to 50 HP	\$50
➤ Compressor-over 50 HP	\$75
➤ Heat pumps – 1.5-15 HP	\$40
• Air handlers (self-contained units, ventilation & exhaust fans) (piping fee included)	
➤ Under 1,500 cfm	\$40
➤ 1,501-10,000 cfm	\$50
➤ Over 10,000 cfm	\$105
➤ Thru-the-wall fan coil vents	\$20
• Breeching & combustion to appliance	\$65
• Chimney – factory built	\$65
• Cooling towers with reservoirs	
➤ Capacity under 500 gal	\$55
➤ Capacity over 500 gal	\$90
• Crematories	\$55
• Ducts, insulation and fire suppression systems (based on bid price)	
➤ Under \$3,000	\$45
➤ \$3,000 to \$7,000	\$55
➤ \$7,000 to \$15,000	\$90
➤ Over \$15,000	\$15 per each \$3,000 over \$15,000 + \$90
• Electronic air cleaner with washer	\$55
• Evaporator coils	
➤ 180,000 BTU and under	\$45
➤ Over 180,000 BTU	\$50
• Fire suppression systems (based on bid prices)	
➤ Under \$2,000	\$80
➤ \$2,000 to \$8,000	\$95
➤ Over \$8,000	\$20 per each \$3,000 over \$8,000 + \$95

• Gas burning equipment (piping fee included)	
➢ 400,000 BTU and under	\$55
➢ Over 400,000 BTU	\$65
• Humidifiers	\$30
• Incinerators – each	\$45
• Inspections – each	\$80
• Insulation – duct, piping, tanks (based on bid price)	
➢ Under \$2,000	\$45
➢ \$2,000 to \$8,000	\$55
➢ Over \$8,000	\$20 per each \$3,000 over \$8,000 + \$55
• License/registration fee	\$0
• LPG & fuel oil tanks (underground add \$10 additional) (piping fee included)	
➢ 276 to 550 gal	\$65
➢ 551 to 2,000 gal	\$105
➢ Each additional tank	Add 50% of fee based on largest tank size
• Oil burner (piping fee included)	
➢ New/conversion, under 5 gal/hour	\$65
➢ New/conversion, over 5 gal/hour	\$95
• Penalty for work prior to obtaining permit	Cost of permit + \$180
• Piping (bid separately) (based on bid price)	
➢ Under \$2,000	\$45
➢ \$2,000 to \$8,000	\$55
➢ Over \$8,000	\$15 per each \$3,000 over \$8,000 + \$55
• Plan review	\$100/hour – minimum 1 hour
• Refrigeration systems	
➢ Under 5 HP (split system)	\$40
➢ 5 HP to 50 HP (split system)	\$50
➢ Over 50 HP (split system)	\$80
➢ Self-contained units	\$55
• Solar equipment/each panel (piping fee included)	\$35
• Unit heaters-hot water, gas or steam (piping fee included)	
➢ 200,000 BTU and under	\$35
➢ Over 200,000 BTU	\$45
<b>5. MECHANICAL – RESIDENTIAL</b>	
• Base fee (non-refundable)	\$40
• Boiler (piping fee included)	
➢ 200,000 BTU and under	\$45
➢ Over 200,000 BTU	\$60
• Central air	\$40
• Dampers (all kinds)	\$20
• Duct system	
➢ Under \$3,000	\$35
➢ \$3,000 to \$7,000	\$40
➢ \$7,000 to \$15,000	\$45
➢ Over \$15,000	\$12 per each \$1,000 over \$15,000 + \$45
• Exhaust fan	\$20
• Gas burning equipment (new and/or conversion) (piping fee included)	
➢ 400,000 BTU and under	\$45
➢ Over 400,000 BTU	\$60
• Gas piping (each outlet)	\$20
• Hotel or motel (per unit)	\$55
• Inspection – each	\$80

• License/registration fee	\$0
• LPG & fuel oil tanks (underground add \$10) (piping fee included)	\$35
• Modular home	\$150
• Oil burner (new and/or conversion) (piping fee included)	\$45
• Penalty for work prior to obtaining permit	Cost of permit + \$180
• Plan review	\$100/hour – 1 hour minimum
• Solar equipment (each panel) (piping fee included)	\$35
• Solid fuel equipment (wood stove, prefab fireplaces, stoves)	\$50
• Two-family dwelling	\$180
• Water heater	\$20
• Whole house permit	\$125
<b>6. PLUMBING</b>	
• Base fee (non-refundable)	\$40
• Fixtures, floor drains, water connected appliances	\$20
• Hotel or motel (per unit)	\$50
• Inspections – each	\$80
• License/registration fee	\$0
• Manholes – catch basins (each)	\$20
• Modular home	\$150
• Penalty for work prior to obtaining permit	Cost of permit + \$180
• Plan review	\$100/hour – 1 hour minimum
• Reduced pressure zone back-flow preventer	\$20
• Sewage ejectors, sumps	\$20
• Sewers	
➢ Connection building drain	\$20
➢ Sanitary, storm or combined (less than 6")	\$20
➢ Sanitary, storm or combined (6" and over)	\$25
• Stacks (soil, waste, vent and conductor)	\$15
• Sub-soil drains	\$20
• Two-family	\$180
• Water distributing pipe	
➢ ¾" – 1"	\$20
➢ 1 ¼"	\$25
➢ 1 ½"	\$35
➢ Over 2"	\$50
• Water service	
➢ Less than 2"	\$20
➢ 2" to 6"	\$30
➢ Over 6"	\$35
• Whole house permit	\$120
<b>7. CITY CLERK</b>	
• Cable television franchise fee	3%
• Marriage fee/presided by Mayor	\$50
<b>8. CITY TREASURER</b>	
• Collection fee tax – administrative fee	1% admin fee on tax bills per Ordinance No. 838
• Property tax late collection fee	
➢ Summer	1% per month September 1 through February 1
➢ Winter and any summer balance	3% additional February 15 <sup>th</sup> –28 <sup>th</sup>
• Return check	As allowed by MCL 600.2952
<b>9. COMMUNITY DEVELOPMENT</b>	

• Credit reports (if not partnered with bank or finance group)	Cost + 25%
• Escrow Fee - Hourly rate of Staff/Consultant involved	\$1,500
• Historic district permit application fee	\$0
• Lot splits	
➢ Single	\$250
➢ Multiple	\$250 each + \$50/resulting lot
• Parking Lease – Downtown	\$20 per month per space (includes signage)
• Parks	
➢ Pavilion reservations	City resident \$25 Non-City resident \$50
• Amphitheater Rental	Tax exempt entity \$50 All other entities \$150
• Mobile Food Vending License	
➢ City-controlled property (May - October)	\$300
➢ City-controlled property (November - April)	\$200
➢ Non-city property (May – October)	\$150
➢ Non-city property (November – April)	\$100
➢ Year-round city food service establishments on city-controlled property (per year)	\$250
➢ Year-round city food service establishments not on city-controlled property (per year)	\$0
• Rental property registration (per unit)	\$50
➢ Non-compliance fee (1 <sup>st</sup> occurrence)	\$200
➢ Non-compliance fee (each additional occurrence)	\$400
• Rezoning request	\$575 + \$10/acre
• Site Plans	
➢ Apartment/townhouse	\$575 + \$5/unit
➢ Commercial/industrial	\$525 + \$50/acre
➢ Institutional (schools, public services, hospitals)	\$500 + \$40/acre
➢ Mobile home park	\$600 + \$5/unit
➢ Planned Unit Development/mixed use development	\$575 + \$50/acre
➢ Preliminary site plan review	75% of site plan review fee
➢ Single family site condo (prelim or final)	\$700 + \$5/lot
➢ Site plan revision/review	75% of site plan review fee + any needed consulting fees determined by administration
➢ Special meeting with planner	All cost by owner/applicant via escrow
• Special land use	\$400 + \$6/acre
• Subdivision	
➢ Preliminary – tentative	\$700 + \$5/lot
➢ Preliminary – final	\$350 + \$2.50/lot
➢ Final plat	\$500 + \$4/lot
• Temporary land use (ZBA review)	\$500
• Use variance	\$700
• Wireless communications equipment and support structures	
➢ Zoning application fee	Administrative costs to review and process application or \$1,000 (whichever is less)
➢ Non-exempt co-locating small cell wireless facilities and support structures	
❖ New wireless support structure or modification of an existing wireless support structure	\$1,000



❖ New small cell wireless support structure or modification of an existing small cell wireless	\$500
➤ Co-locate a small cell wireless facility and/or associated support structure application fee shall not exceed and shall be set as follows:	
❖ Each small cell wireless facility alone	\$200
❖ Each small cell wireless facility and a new utility pole or wireless support to which it will be attached	\$300
➤ Annual permit fee for each utility pole or wireless support structure in ROW on which a wireless provider has approval to co-locate a small cell wireless facility shall not exceed and shall be set as follows:	
❖ Annually, unless the following applies	\$20
❖ If the utility pole or wireless support structure was erected by or on behalf of the wireless provider on or after March 12, 2019	\$125
• Zoning variance	
➤ Commercial	\$425
➤ Residential	\$200
<b>10. GENERAL</b>	
• Notary (maximum of 3 signatures per fee)	
➤ Non-resident	\$10
➤ Resident	\$5
• Rental conference room between 8:00 am and 5:00 pm	
➤ ½ day up to four hours	\$30
➤ Full day	\$60
➤ Organization of which the city is a member	\$0
• Rental council chambers between 8:00 am and 5:00 pm	
➤ ½ day up to four hours	\$30
➤ Full day	\$60
➤ Organization of which the city is a member	\$0
<b>11. HISTORICAL COMMISSION – Funds go to Historical Commission</b>	
• Admission Curwood Castle	
➤ Adult	Donation request \$5
➤ Child	Donation request \$2
• Rental Curwood Castle	
➤ First hour	(\$50 refundable) \$250
➤ Each additional hour	\$55
• <del>Rental Gould House</del>	
➤ <del>First hour</del>	<del>(\$50 refundable) \$250</del>
➤ <del>Each additional hour</del>	<del>\$55</del>
• <del>Rental Gould House apartment #2</del>	
➤ <del>Per month</del>	<del>\$750</del>
➤ <del>Note: reduction in rate if long term</del>	<del>\$700</del>
• <del>Rental Gould House apartment #3</del>	
➤ <del>Per month</del>	<del>\$750</del>
➤ <del>Note: reduction in rate if long term</del>	<del>\$700</del>
<b>12. PUBLIC SAFETY</b>	
• Ambulance fees – adjusted to the screen rates approved by commercial insurance companies	
➤ In-facility transports	\$250.80
• False alarm fee – fee may be waived by authority of Public Safety Director. First two fire and police alarms are not fined. The occupant will be notified of the 1 <sup>st</sup> or 2 <sup>nd</sup> violation by letter	
➤ False alarm FIRE: 3 <sup>rd</sup> call	\$250
➤ False alarm FIRE: 4 <sup>th</sup> and subsequent fire alarms	\$500
➤ False alarm POLICE: 3 <sup>rd</sup> call	\$50
➤ False alarm POLICE: 4 <sup>th</sup> and subsequent police alarms	\$100
• Fire Inspection Fees	

➤ Annual fire inspection	\$0
➤ Fire alarm field test	\$100
➤ Certificate of occupancy	\$100
➤ Change in liquor license site inspection	\$150
➤ Sprinkler system hydrostatic test (per riser)	\$100
➤ Observe fire flow test	\$100
➤ Tent Permit	\$125
• Fire Plan Review, Permit and Inspection schedule	\$100
➤ Plan review for fire alarm system (fee based on square footage)	
❖ 0 – 2,500 sq. ft.	\$100
❖ 2,500 – 10,000 sq. ft.	\$200
❖ 10,001 – 50,000 sq. ft.	\$250
❖ Over 50,000 sq. ft.	\$500
• Fire run	\$500
• Gun registration	\$10
• Peddler's permit	
➤ Per month	\$50
➤ Per year (expiring December 31 <sup>st</sup> )	\$200
• Portable breath test (PBT)	
➤ ½ month	\$15
➤ Full month	\$30
• Sex offender initial registration	\$35
• Traffic Control Order	
➤ Traffic Control Order Application	\$30
➤ MDOT Closure Application	\$50
➤ Expedited Application Fee (if submitted 14-29 days prior to first day of event)	\$15 additional
➤ Fire truck	\$150 per event
<b>13. PARKING FINES – DEFINED IN SECTION 33 OF THE OWOSSO MUNICIPAL CODE</b>	
• Abandoned car	
➤ Paid within 7 days	\$15
➤ Paid within 14 days	\$30
➤ Paid within 30 days	\$45
• Across parking line	
➤ Paid within 7 days	\$15
➤ Paid within 14 days	\$30
➤ Paid within 30 days	\$45
• Blocking alley	
➤ Paid within 7 days	\$15
➤ Paid within 14 days	\$30
➤ Paid within 30 days	\$45
• Blocking driveway	
➤ Paid within 7 days	\$15
➤ Paid within 14 days	\$30
➤ Paid within 30 days	\$45
• Blocking traffic	
➤ Paid within 7 days	\$15
➤ Paid within 14 days	\$30
➤ Paid within 30 days	\$45
• Double parking	
➤ Paid within 7 days	\$15
➤ Paid within 14 days	\$30
➤ Paid within 30 days	\$45

• Electric Vehicle Parking: Public use charging stations shall be reserved for parking and charging electric vehicles only	
➤ Paid within 7 days	\$30
➤ Paid within 14 days	\$45
➤ Paid within 30 days	\$60
• Fifth violation of any above violations within a 30-day period	
➤ Paid within 7 days	\$100
➤ Paid within 14 days	\$100
➤ Paid within 30 days	\$100
• Moving to evade time limitations	
➤ Paid within 7 days	\$15
➤ Paid within 14 days	\$30
➤ Paid within 30 days	\$45
• Other parking violation	
➤ Paid within 7 days	\$15
➤ Paid within 14 days	\$30
➤ Paid within 30 days	\$45
• Overnight parking in 3:00 am to 6:00 am zone	
➤ Paid within 7 days	\$15
➤ Paid within 14 days	\$30
➤ Paid within 30 days	\$45
• Parked facing wrong way	
➤ Paid within 7 days	\$15
➤ Paid within 14 days	\$30
➤ Paid within 30 days	\$45
• Parking in prohibited zone	
➤ Paid within 7 days	\$15
➤ Paid within 14 days	\$30
➤ Paid within 30 days	\$45
• Parking in loading zone	
➤ Paid within 7 days	\$15
➤ Paid within 14 days	\$30
➤ Paid within 30 days	\$45
• Parking on sidewalk or crosswalk	
➤ Paid within 7 days	\$15
➤ Paid within 14 days	\$30
➤ Paid within 30 days	\$45
• Parked at yellow curb	
➤ Paid within 7 days	\$15
➤ Paid within 14 days	\$30
➤ Paid within 30 days	\$45
• Parked in handicap zone	
➤ Paid within 7 days	\$50
➤ Paid within 14 days	\$100
➤ Paid within 30 days	\$100
• Parked within 15 feet of fire hydrant	
➤ Paid within 7 days	\$15
➤ Paid within 14 days	\$30
➤ Paid within 30 days	\$45
• Parking over 12 inches from curb	
➤ Paid within 7 days	\$15
➤ Paid within 14 days	\$30
➤ Paid within 30 days	\$45

• Parked over legal limit in areas other than business districts defined in sec. 33-37	
➤ Paid within 7 days	\$15
➤ Paid within 14 days	\$30
➤ Paid within 30 days	\$45
• Parked over legal limit in business districts defined in sec. 33-37 – 3 <sup>rd</sup> & subsequent violations in each calendar year	
➤ Paid within 7 days	\$15
➤ Paid within 14 days	\$30
➤ Paid within 30 days	\$45
• Parking of a truck or commercial vehicle with a gross weight in excess of 5 tons or in excess of 22 feet in length in violation of the provisions of section 5.61 of the Uniform Traffic Code	
➤ Paid within 7 days	\$25
➤ Paid within 14 days	\$50
➤ Paid within 30 days	\$75
<b>14. VIOLATIONS/FINES</b>	
• Bonfire permit	\$0
• Misdemeanor “see ordinance/code under (b)”	\$500 + other stipulations
• Municipal civil infraction	
➤ First offense	\$50
➤ Second offense	\$250
➤ Third or subsequent repeat offenses	\$500
• Municipal civil infraction – loose dogs Code states: If the dog was impounded by any police officer or other authorized employee of the city, the owner shall pay the additional sum to the city to reimburse for said expense as prescribed by resolution of the council	\$50 + pound fees
<b>15. PUBLIC SERVICES</b>	
• Copies of building plans/blueprints	Per page \$10
• Mowing	Cost + \$100
• Right of way permit	
➤ Inspection fee	\$50
• Snow removal	Cost + \$100
• METRO Act permit application fee	Per statute

*I hereby certify that the foregoing document is a true and complete copy of action taken by the Owosso City Council at the regular meeting of November 4, 2024.*

---

*Amy K. Kirkland, City Clerk*

Check Date	Check	Vendor Name	Invoice Vendor	Description	Amount
Bank 1 GENERAL FUND (POOLED CASH)					
10/11/2024	11030 (E)	HUNTINGTON NATONAL BANK -CREDI	HUNTINGTON NATONAL BANK -CREDI	CITY CREDIT CARD PURCHASES	6,741.42
10/11/2024	11031 (E)	MAILCHIMP	MAILCHIMP	MAILCHIMP CONTACTS	17.00
10/11/2024	11032 (A)	AMAZON CAPITAL SERVICES	AMAZON CAPITAL SERVICES	SEPTEMBER 2024 AMAZON PURCHASES	147.97
			AMAZON CAPITAL SERVICES	SEPTEMBER 2024 AMAZON PURCHASES	37.88
			AMAZON CAPITAL SERVICES	SEPTEMBER 2024 AMAZON PURCHASES	95.53
			AMAZON CAPITAL SERVICES	SEPTEMBER 2024 AMAZON PURCHASES	330.36
			AMAZON CAPITAL SERVICES	AUGUST 2024 PURCHASES	17.97
					<u>629.71</u>
10/11/2024	11033 (A)	BELL EQUIPMENT - MACQUEEN	BELL EQUIPMENT - MACQUEEN	#442 PARTS	399.02
10/11/2024	11034 (A)	BRUCKMAN'S MOVING & STORAGE	SEBRUCKMAN'S MOVING & STORAGE	SEDDA MONTHLY STORAGE JULY 2024 - JUNE	200.00
10/11/2024	11035 (A)	CAPITAL CITY SCUBA INC	CAPITAL CITY SCUBA INC	REFILL/REPAIR SCUBA GEAR	70.00 V
		Void Reason: BAD ACH ACCOUNT			
10/11/2024	11036 (A)	CDW GOVERNMENT, INC.	CDW GOVERNMENT, INC.	APC REPLACEMENT BATTERY CARTRIDGE #1	91.91
			CDW GOVERNMENT, INC.	CRADLEPOINT NETCLOUD SUBSCRIPTION -	1,320.00
					<u>1,411.91</u>
10/11/2024	11037 (A)	CINTAS CORPORATION #308	CINTAS CORPORATION #308	FLOOR MATS PER SERVICE AGREEMENT (US	38.32
			CINTAS CORPORATION #308	FLOOR MATS PER SERVICE AGREEMENT (US	38.32
					<u>76.64</u>
10/11/2024	11038 (A)	CMP DISTRIBUTORS INC	CMP DISTRIBUTORS INC	DUTY BELT/UNDERBELT/BELT HARNESS-PET	208.75
			CMP DISTRIBUTORS INC	HANDCUFF CASE REPLACEMENT/PETTIGREW	24.50
					<u>233.25</u>
10/11/2024	11039 (A)	CONSUMERS ENERGY	CONSUMERS ENERGY	CITY OF OWOSSO ACCOUNTS	49,334.61
10/11/2024	11040 (A)	CRUISERS INC	CRUISERS INC	PRINTER REPLACEMENT CAR 24-06	615.66
10/11/2024	11041 (A)	DALTON ELEVATOR LLC	DALTON ELEVATOR LLC	FYE6-30-2025 CYLINDER RENTAL/OXYGEN/	370.76
10/11/2024	11042 (A)	DANIEL MILLER	DANIEL MILLER	MEAL REIMBURSEMENTS FROM TRAINING	38.67
10/11/2024	11043 (A)	DELAU FIRE & SAFETY INC	DELAU FIRE & SAFETY INC	ANNUAL INSPECT OF FIRE EX.	60.00
			DELAU FIRE & SAFETY INC	SEMI-ANNUAL COMPUTER ROOM FIRE SUPRE	282.00
					<u>342.00</u>
10/11/2024	11044 (A)	EDWARDS SIGN & SCREEN PRINTING	EDWARDS SIGN & SCREEN PRINTING	BUILDING OFFICIAL HATS WITH CITY LOG	61.00
			EDWARDS SIGN & SCREEN PRINTING	SIGNS FOR BENTLEY AND CURWOOD PARKS	250.00
					<u>311.00</u>
10/11/2024	11045 (A)	ELECTION SOURCE	ELECTION SOURCE	BALLOT TEST CHARTS -- NOV 5, 2024 GE	170.00
			ELECTION SOURCE	VOTING BOOTH LIGHTS	277.20
					<u>447.20</u>
10/11/2024	11046 (A)	ENG INC	ENG INC	STEWART STREET PRE ENGINEERING WATEF	15,862.88
10/11/2024	11047 (A)	FASTENAL COMPANY	FASTENAL COMPANY	SS BOLTS NEEDED FOR WTR STOCK INV.	179.93
10/11/2024	11048 (A)	FERGUSON ENTERPRISES LLC	FERGUSON ENTERPRISES LLC	WATER INVENTORY-PURCHASE NOT TO EXCE	611.00
			FERGUSON ENTERPRISES LLC	WATER INVENTORY-PURCHASE NOT TO EXCE	338.00
			FERGUSON ENTERPRISES LLC	MAY INV REPLACEMENT WTR	33.00
			FERGUSON ENTERPRISES LLC	JULY STOCK REPLACEMENT PARTS ORDER	2,342.88

Check Date	Check	Vendor Name	Invoice Vendor	Description	Amount
			FERGUSON ENTERPRISES LLC	SRI BACKFLOW PREVENTER AND STRAINER	13,700.00
			FERGUSON ENTERPRISES LLC	SRI BACKFLOW PREVENTER AND STRAINER	3,750.00
			FERGUSON ENTERPRISES LLC	STOCK AND INVENTORY	205.00
			FERGUSON ENTERPRISES LLC	JULY STOCK REPLACEMENT PARTS ORDER	350.00
			FERGUSON ENTERPRISES LLC	EOM APRIL INVENTORY.	546.00
			FERGUSON ENTERPRISES LLC	8" TAPING VALVE	1,764.26
					<u>23,640.14</u>
10/11/2024	11049 (A)	FISHBECK, THOMPSON, CARR & HUB	FISHBECK, THOMPSON, CARR & HUB	ENGINEERING SERVICES FOR WWTP SOLIDS	723.50
			FISHBECK, THOMPSON, CARR & HUB	WWTP FILTERS IMPROVEMENT PROJECT DWRF	1,241.49
			FISHBECK, THOMPSON, CARR & HUB	WWTP PHASE 1 PREENGINEERING WORK (CW	11,539.09
					<u>13,504.08</u>
10/11/2024	11050 (A)	FISHER SCIENTIFIC CO.	FISHER SCIENTIFIC CO.	SELECTED ITEMS FROM 2024 ANNUAL LAB	9.64
			FISHER SCIENTIFIC CO.	SELECTED ITEMS FROM 2024 ANNUAL LAB	1,334.53
					<u>1,344.17</u>
10/11/2024	11051 (A)	GILBERT'S DO IT BEST HARDWARE	GILBERT'S DO IT BEST HARDWARE	SEPTEMBER 2024 PURCHASES	722.95
10/11/2024	11052 (A)	GROUP RESOURCES	GROUP RESOURCES	GROUP FSA ADMIN FEE	100.00
10/11/2024	11053 (A)	H2O COMPLIANCE SERVICES INC	H2O COMPLIANCE SERVICES INC	H2O CROSS CONNECTION CONTROL PROGRAM	767.81
10/11/2024	11054 (A)	HARBOR FREIGHT TOOLS	HARBOR FREIGHT TOOLS	TOOLS FOR DPW/WATER	205.86
10/11/2024	11055 (A)	HUNTINGTON NATIONAL BANK	HUNTINGTON NATIONAL BANK	ACCOUNT # 3584277907 OWOSSOMIUT21	136,325.00
10/11/2024	11056 (A)	HUNTINGTON NATIONAL BANK	HUNTINGTON NATIONAL BANK	ACCOUNT# 3584278005 OWOSSOMILT21	6,400.00
10/11/2024	11057 (A)	HURON & EASTERN RAILWAY COMPAN	HURON & EASTERN RAILWAY COMPAN	PIPE LINE CROSSING - 11/1/23-10/31/2	884.46
10/11/2024	11058 (A)	HUTSON INC OF MICHIGAN	HUTSON INC OF MICHIGAN	FYE6-30-2025 ROUTINE PARTS/SUPPLIES-	1,906.55
10/11/2024	11059 (A)	J & H OIL COMPANY	J & H OIL COMPANY	GAS AND FUEL	5,660.90
			J & H OIL COMPANY	FYE6-30-2025 LUBES AND DELIVERED DIE	792.25
					<u>6,453.15</u>
10/11/2024	11060 (A)	JCI JONES CHEMICALS INC	JCI JONES CHEMICALS INC	SODIUM HYPOCHLORITE - WWTP FYE6-30-2	4,785.64
			JCI JONES CHEMICALS INC	SODIUM HYPOCHLORITE - WTP FYE6-30-2C	3,348.50
					<u>8,134.14</u>
10/11/2024	11061 (A)	JON HARRIS	JON HARRIS	ELECTRICAL INPECTIONS SEPT. 2024	765.88
			JON HARRIS	ELECTRICL PLAN REVIEWS SEPT. 2024	450.00
					<u>1,215.88</u>
10/11/2024	11062 (A)	LADY LIBERTY EQUIPMENT	LADY LIBERTY EQUIPMENT	CORE CUT MODEL CC3538JK-26 SELF PROF	17,925.00
10/11/2024	11063 (A)	MACQUEEN EMERGENCY GROUP	MACQUEEN EMERGENCY GROUP	STRUCTURAL FIREFIGHTING GEAR CONTRAC	4,766.42
			MACQUEEN EMERGENCY GROUP	STRUCTURAL FIREFIGHTING GEAR CONTRAC	2,390.58
					<u>7,157.00</u>
10/11/2024	11064 (A)	MARK BOOTH	MARK BOOTH	PLUMBING AND MECHANICAL PLAN REVIEWS	900.00
			MARK BOOTH	MECHANICAL & PLUMBING INSPECTIONS	2,340.00
					<u>3,240.00</u>
10/11/2024	11065 (A)	MEMORIAL HEALTHCARE	MEMORIAL HEALTHCARE	PREEMPLOYMENT DRUG SCREENS	345.00
10/11/2024	11066 (A)	MUNICIPAL EMPLOYEES RETIREMENT	MUNICIPAL EMPLOYEES RETIREMENT	EMPLOYER CONTRIBUTIONS	66,088.50
10/11/2024	11067 (A)	NAPA AUTO PARTS	NAPA AUTO PARTS	PARTS/SUPPLIES-INVOICE TO BE SIGNED	487.11
10/11/2024	11068 (A)	NCL OF WISCONSIN INC	NCL OF WISCONSIN INC	SELECTED ITEMS FROM 2024 ANNUAL LAB	88.17

Check Date	Check	Vendor Name	Invoice Vendor	Description	Amount
			NCL OF WISCONSIN INC	SELECTED ITEMS FROM 2024 ANNUAL LAB	1,550.75
					<u>1,638.92</u>
10/11/2024	11069 (A)	NEOGEN CORPORATION	NEOGEN CORPORATION	COLITAG P/A WATER TEST KIT (PACK OF	1,209.80
10/11/2024	11070 (A)	OCENASEK INC	OCENASEK INC	FYE 6-30-2025 - 21AA LIMESTONE / 6P	4,193.59
10/11/2024	11071 (A)	PHP MEDICARE	PHP MEDICARE	NOV. 2024 MEDICARE PAYMENT	88.00
10/11/2024	11072 (A)	PVS NOLWOOD CHEMICALS INC	PVS NOLWOOD CHEMICALS INC	SODIUM FLOURIDE	1,699.00
10/11/2024	11073 (A)	PVS TECHNOLOGIES, INC.	PVS TECHNOLOGIES, INC.	FERRIC CHLORIDE AT WWTP FYE 6-30-202	9,983.86
10/11/2024	11074 (A)	QUADIANT FINANCE USA INC	QUADIANT FINANCE USA INC	POSTAGE USED AUGUST 2024 ACCT# 7900C	2,175.75
10/11/2024	11075 (A)	REPUBLIC SERVICES INC	REPUBLIC SERVICES INC	REFUSE SERVICE 7/1/23-6/30/24 PER BI	435.99
10/11/2024	11076 (A)	RUTHY'S LAUNDRY CENTER	RUTHY'S LAUNDRY CENTER	PUBLIC SAFETY UNIFORM CLEANING	865.80
10/11/2024	11077 (A)	SMITH SAND & GRAVEL INC	SMITH SAND & GRAVEL INC	22A GRAVEL - ESTIMATE QUANTITY - FYE	1,823.25
			SMITH SAND & GRAVEL INC	CLASS II BACK FILL SAND - FYE 6-30-2	<u>2,133.66</u>
					3,956.91
10/11/2024	11078 (A)	SOLARWINDS	SOLARWINDS	RENEWAL OF SOLARWINDS TECH LICENSES	182.00
10/11/2024	11079 (A)	SORENSEN GROSS COMPANY	SORENSEN GROSS COMPANY	OWOSSO WWTP SOLIDS HANDLING PROJECT	114,891.69
10/11/2024	11080 (A)	SPICER GROUP, INC.	SPICER GROUP, INC.	ENGINEERING SERVICES FOR SAFET ROUTE	50,208.25
10/11/2024	11081 (A)	STAPLES BUSINESS CREDIT	STAPLES BUSINESS CREDIT	SEPTEMBER 2024 PURCHASES	366.53
			STAPLES BUSINESS CREDIT	AUGUST 2024 PURCHASES	166.49
			STAPLES BUSINESS CREDIT	JULY 2024 MONTHLY PURCHASES	65.68
					<u>598.70</u>
10/11/2024	11082 (A)	SUMMIT COMPANIES	SUMMIT COMPANIES	FIRE EXTINGUISHER INPECTION - CASTLE	89.00
10/11/2024	11083 (A)	TAYLOR AND MORGAN CPA PC	TAYLOR AND MORGAN CPA PC	ACCOUNTANT SERVICES JANUARY 2024-DEC	2,581.25
10/11/2024	11084 (A)	TETRA TECH INC	TETRA TECH INC	DEVELOPMENT OF A WATER TREATMENT PLA	9,500.00
10/11/2024	11085 (A)	THE ARGUS-PRESS	THE ARGUS-PRESS	LEGAL PRINTING SERVICES 2 YEARS	252.33
10/11/2024	11086 (A)	THOMAS SCIENTIFIC	THOMAS SCIENTIFIC	SELECTED ITEMS FROM 2024 ANNUAL LAB	17.20
			THOMAS SCIENTIFIC	SELECTED ITEMS FROM 2024 ANNUAL LAB	108.33
			THOMAS SCIENTIFIC	SELECTED ITEMS FROM 2024 ANNUAL LAB	229.41
			THOMAS SCIENTIFIC	SELECTED ITEMS FROM 2024 ANNUAL LAB	101.96
			THOMAS SCIENTIFIC	SELECTED ITEMS FROM 2024 ANNUAL LAB	380.66
					<u>837.56</u>
10/11/2024	11087 (A)	TOTAL ENERGY SYSTEMS LLC	TOTAL ENERGY SYSTEMS LLC	PLANNED MAINTENANCE OF OFD GENERATOR	852.00
10/11/2024	11088 (A)	UNIQUE PAVING MATERIALS CORP	UNIQUE PAVING MATERIALS CORP	COLD PATCH	6,784.49
10/11/2024	11089 (A)	USA BLUE BOOK	USA BLUE BOOK	SELECTED ITEMS FROM 2024 ANNUAL LAB	5,130.05
			USA BLUE BOOK	H2S CHART RECORDER AND ACCESSORIES	1,080.35
			USA BLUE BOOK	ROUTINE PURCHASES NOT TO EXCEED \$20C	123.00
			USA BLUE BOOK	ROUTINE PURCHASES NOT TO EXCEED \$20C	1,850.95
					<u>8,184.35</u>
10/11/2024	11090 (A)	WASTE MANAGEMENT OF MICHIGAN	IWASTE MANAGEMENT OF MICHIGAN	IWASTE MANAGEMENT SERVICES	7,275.59
10/25/2024	11091 (A)	ABSOPURE WATER COMPANY LLC	ABSOPURE WATER COMPANY LLC	FYE6-30-2025 WATER FOR LAB USE ONLY.	150.95
10/25/2024	11092 (A)	ALS LABORATORY GROUP	ALS LABORATORY GROUP	FYE 6-30-2025 WASTEWATER ANALYSES-ES	185.00
10/25/2024	11093 (A)	AMAZON CAPITAL SERVICES	AMAZON CAPITAL SERVICES	SEPTEMBER 2024 AMAZON PURCHASES	173.94
			AMAZON CAPITAL SERVICES	AUGUST 2024 PURCHASES	323.34
			AMAZON CAPITAL SERVICES	SEPTEMBER 2024 AMAZON PURCHASES	99.58
			AMAZON CAPITAL SERVICES	SEPTEMBER 2024 AMAZON PURCHASES	169.89
			AMAZON CAPITAL SERVICES	AUGUST 2024 PURCHASES	19.15
			AMAZON CAPITAL SERVICES	OCTOBER 2024 REGULAR PURCHASES	69.99
			AMAZON CAPITAL SERVICES	OCTOBER 2024 REGULAR PURCHASES	174.16
					<u>1,030.05</u>

CHECK REGISTER FOR CITY OF OWOSSO  
 CHECK DATE FROM 10/01/2024 - 10/31/2024

Check Date	Check	Vendor Name	Invoice Vendor	Description	Amount
10/25/2024	11094 (A)	AXON ENTERPRISE INC	AXON ENTERPRISE INC	2 BODY CAMERAS/SOFTWARE/HARDWARE	4,941.03
10/25/2024	11095 (A)	BOUND TREE MEDICAL LLC	BOUND TREE MEDICAL LLC	MEDICAL SUPPLIES	936.39
10/25/2024	11096 (A)	BRUCKMAN'S MOVING & STORAGE	SEBRUCKMAN'S MOVING & STORAGE	SEDDA MONTHLY STORAGE JULY 2024 - JUNE	200.00
10/25/2024	11097 (A)	CDW GOVERNMENT, INC.	CDW GOVERNMENT, INC.	ADOBE ACROBAT STANDARD 1 USER	165.45
10/25/2024	11098 (A)	CINTAS CORPORATION #308	CINTAS CORPORATION #308	FLOOR MATS PER SERVICE AGREEMENT (US	38.32
10/25/2024	11099 (A)	COMMUNITY IMAGE BUILDERS	COMMUNITY IMAGE BUILDERS	PLANNING, ZONING & DEVELOPMENT ADVIS	826.50
10/25/2024	11100 (A)	CURB APPEAL PROPERTY MAINTENAN	CURB APPEAL PROPERTY MAINTENAN	2024 NEP GRANT	11,147.00
10/25/2024	11101 (A)	DELL MARKETING LP	DELL MARKETING LP	FILTRAT CNTRL UPGRADE HARDWARE & SOF	42,087.72
10/25/2024	11102 (A)	EJ USA INC	EJ USA INC	FIRE HYDRANT PARTS INV.	737.68
10/25/2024	11103 (A)	ENG INC	ENG INC	ENGINEERING-2023 NORTH STREET PROJEC	62.50
			ENG INC	ENGINEERING SERVICE SFOR 2024 DWRSF	20,263.44
			ENG INC	STEWART STREET PRE ENGINEERING WATEF	17,822.30
					<u>38,148.24</u>
10/25/2024	11104 (A)	ESO SOLUTIONS INC	ESO SOLUTIONS INC	ESO FIRE INCIDENTS SUBSCRIPTION 11/C	1,603.29
10/25/2024	11105 (A)	FASTENAL COMPANY	FASTENAL COMPANY	PARTS FOR INTERMEDIATE CLARIFIER WEA	633.70
10/25/2024	11106 (A)	FERGUSON ENTERPRISES INC	FERGUSON ENTERPRISES INC	8" MEGA LUGS AND HYDRANT MARKERS	363.36
10/25/2024	11107 (A)	FLEIS & VANDENBRINK ENGINEERIN	FLEIS & VANDENBRINK ENGINEERIN	ENGINEERING - CIS TRAIL CONNECTION F	4,592.00
10/25/2024	11108 (A)	GLAESER DAWES CORP	GLAESER DAWES CORP	2024 WATERMAIN REPLACEMENT (DWR7497	133,646.91
			GLAESER DAWES CORP	2024 WATERMAIN REPLACEMENT (DWR7497	93,938.30
					<u>227,585.21</u>
10/25/2024	11109 (A)	GRAYMONT WESTERN LIME INC	GRAYMONT WESTERN LIME INC	LIME FOR WTP FYE6-30-2025	8,860.32
10/25/2024	11110 (A)	GREEN TECH SYSTEMS LLC	GREEN TECH SYSTEMS LLC	TRENCHLESS EMERGENCY WATER SERVICE I	9,922.00
10/25/2024	11111 (A)	HANNA INSTRUMENTS INC	HANNA INSTRUMENTS INC	HI70480U PCA FREE CHLORINE REAGENT K	599.90
10/25/2024	11112 (A)	HIGHWAY MAINTENANCE & CONSTRU	HIGHWAY MAINTENANCE & CONSTRU	FY2024-2025 CHIP SEAL PROJECT	74,090.36
				FY2024-2025 CHIP SEAL PROJECT	16,831.29
					<u>90,921.65</u>
10/25/2024	11113 (A)	IDEXX DISTRIBUTION CORPORATION	IDEXX DISTRIBUTION CORPORATION	WP104 COLI P/A COMPARATOR	27.26
10/25/2024	11114 (A)	INTEGRITY BUSINESS SOLUTIONS I	INTEGRITY BUSINESS SOLUTIONS I	COPY PAPER FOR CITY HALL QUOTE # 357	174.95
10/25/2024	11115 (A)	KEYES QUALITY CONSTRUCTION LLC	KEYES QUALITY CONSTRUCTION LLC	2024 NEP GRANT RECIPENTS - INDIVIDUA	11,158.86
10/25/2024	11116 (A)	LANSING UNIFORM CO.	LANSING UNIFORM CO.	REPLACEMENT NAME PLATES	1,380.45
			LANSING UNIFORM CO.	UNIFORMS FOR OFD	420.65
					<u>1,801.10</u>
10/25/2024	11117 (A)	LUDINGTON ELECTRIC, INC.	LUDINGTON ELECTRIC, INC.	REWORK OF GILBERTS PARKING LOT LIGHT	1,920.00
			LUDINGTON ELECTRIC, INC.	OSBURN WELL CE TRANSFORMER REPLACE/I	2,950.00
			LUDINGTON ELECTRIC, INC.	BALL STREET LIGHTS REPAIR	575.00
			LUDINGTON ELECTRIC, INC.	LIGHTS FOR S. PLAZA LOT PLUGS	1,100.00
			LUDINGTON ELECTRIC, INC.	RE ENERGIZE ALL CHAIRMAN LIGHTS COMS	1,450.00
					<u>7,995.00</u>
10/25/2024	11118 (A)	LUNGHAMER FORD OF OWOSSO	LUNGHAMER FORD OF OWOSSO	2016 F-350 SERVICE WHEEL HUB, HUB LC	951.60
			LUNGHAMER FORD OF OWOSSO	MPI AND OIL CHANGE 2018 F150	87.76
					<u>1,039.36</u>
10/25/2024	11119 (A)	MEMORIAL HEALTHCARE WELLNESS C	MEMORIAL HEALTHCARE WELLNESS C	MEMBERSHIP FEES NOV. 2024	214.00
10/25/2024	11120 (A)	MERIT LABORATORIES INC	MERIT LABORATORIES INC	FYE6-30-2025 ANNUAL WATER TESTING SE	128.00
			MERIT LABORATORIES INC	FYE6-30-2025 ANNUAL WATER TESTING SE	80.00
					<u>208.00</u>



Check Date	Check	Vendor Name	Invoice Vendor	Description	Amount
10/25/2024	11121 (A)	MERKEL AND KENNEY INC	MERKEL AND KENNEY INC	MI HOPE GRANT ARP202337MIH	13,947.75
			MERKEL AND KENNEY INC	MI HOPE GRANT ARP202337MIH	11,071.50
			MERKEL AND KENNEY INC	MI HOPE GRANT ARP202337MIH	7,241.00
			MERKEL AND KENNEY INC	MI HOPE GRANT ARP202337MIH	4,500.00
					<u>36,760.25</u>
10/25/2024	11122 (A)	MERLE BOES INC	MERLE BOES INC	SHELL GADUS GREASE FOR SCREWPUMPS	1,339.52
10/25/2024	11123 (A)	METTLER-TOLEDO INC.	METTLER-TOLEDO INC.	ANNUAL SERVICE/CALIBRATION ON ANALY	302.69
10/25/2024	11124 (A)	NORTHERN PUMP & WELL INC	NORTHERN PUMP & WELL INC	PROPOSAL 24-Q3150 TO CLEAN INSPECT F	39,418.00
10/25/2024	11125 (A)	OCENASEK INC	OCENASEK INC	HARMON PATRIDGE 3/8 MINUS- LIMESTON	3,161.73
10/25/2024	11126 (A)	ODEN TRAINING	ODEN TRAINING	TRAINING CLASS FOR F4 EXAM	250.00
10/25/2024	11127 (A)	PHP INSURANCE COMPANY	PHP INSURANCE COMPANY	HEALTH INSURANCE PREMIUM	105,388.73
10/25/2024	11128 (A)	PRINTING SYSTEMS, INC.	PRINTING SYSTEMS, INC.	EV BLANK BALLOT STOCK	60.11
10/25/2024	11129 (A)	RCL CONSTRUCTION CO INC	RCL CONSTRUCTION CO INC	WWTP IMPROVEMENTS PHASE 1 - CWRP PRC	1,166,904.05 V
			Void Reason: PAYING AT A LATER DATE		
10/25/2024	11130 (A)	SAFEUILT LLC LOCKBOX #88135	SAFEUILT LLC LOCKBOX #88135	ANNUAL CONTRACT FYE 6-30-2024 - WOF	12,552.51
10/25/2024	11131 (A)	SP POWELLS SAND AND SOIL LLC	SP POWELLS SAND AND SOIL LLC	609 MARTIN STREET - COURT ORDERED RE	8,050.00
10/25/2024	11132 (A)	SUMMIT COMPANIES	SUMMIT COMPANIES	ANNUAL EXTINGUISHER INSPECTION/PM	532.00
10/25/2024	11133 (A)	SUSAN J. OSIKA	SUSAN J. OSIKA	REIMBURSEMENT FOR FLOWERS - HOME TOU	50.00
10/25/2024	11134 (A)	TAPHOUSE SPECIALTY MEAT MARKET	TAPHOUSE SPECIALTY MEAT MARKET	VOLUNTEER APPRECIATION PARTY SUPPLIE	146.22
			TAPHOUSE SPECIALTY MEAT MARKET	VOLUNTEER APPRECIATION PARTY SUPPLIE	20.00
					<u>166.22</u>
10/25/2024	11135 (A)	THE ACCUMED GROUP	THE ACCUMED GROUP	BILLING SERVICE COLLECTION FEE	4,926.55
10/25/2024	11136 (A)	ULINE	ULINE	8 TRASH CANS FOR PARKS	1,656.32
10/25/2024	11137 (A)	UNITED PARCEL SERVICE	UNITED PARCEL SERVICE	SHIPPING FOR WWTP	13.28
10/25/2024	11138 (A)	VERIZON WIRELESS	VERIZON WIRELESS	VERIZON WIRELESS CELLULAR CHARGES: F	541.70
			VERIZON WIRELESS	VERIZON WIRELESS CELLULAR CHARGES: C	86.68
			VERIZON WIRELESS	VERIZON WIRELESS CELLULAR CHARGES H.	40.72
			VERIZON WIRELESS	VERIZON WIRELESS CELLULAR CHARGES: F	711.07
			VERIZON WIRELESS	VERIZON WIRELESS CELLULAR CHARGES: E	86.44
			VERIZON WIRELESS	VERIZON WIRELESS CELLULAR CHARGES: E	43.34
			VERIZON WIRELESS	VERIZON WIRELESS CELLULAR CHARGES: F	89.06
			VERIZON WIRELESS	VERIZON WIRELESS CELLULAR CHARGES: I	185.50
			VERIZON WIRELESS	VERIZON WIRELESS CELLULAR CHARGES: W	107.68
			VERIZON WIRELESS	VERIZON WIRELESS CELLULAR CHARGES: W	134.02
			VERIZON WIRELESS	VERIZON WIRELESS CELLULAR CHARGES: I	43.34
					<u>2,069.55</u>
10/25/2024	11139 (A)	WASTE MANAGEMENT OF MICHIGAN	WASTE MANAGEMENT OF MICHIGAN	IWASTE MANAGEMENT SERVICES	8,359.39
10/25/2024	11140 (A)	WOODBURY LAWN & SNOW SERVICES,	WOODBURY LAWN & SNOW SERVICES,	2024 PRIVATE PROPERTY MOWING CONTRAC	220.00
10/25/2024	11141 (E)	MAILCHIMP	MAILCHIMP	EMAIL SERVICE - ESSENTIALS PLAN	19.50
10/25/2024	11142 (E)	USDA RURAL DEVELOPMENT	USDA RURAL DEVELOPMENT	USDA RURAL DEVELOPMENT LOAN PAYMENT	1,141.87
10/28/2024	11143 (A)	RCL CONSTRUCTION CO INC	RCL CONSTRUCTION CO INC	WWTP IMPROVEMENTS PHASE 1 - CWRP PRC	1,166,904.05
10/11/2024	137700	319 RIDGE ST LLC	319 RIDGE ST LLC	UB refund for account: 2612490009	5.92
10/11/2024	137701	AGNEW SIGNS - MARK D AGNEW	AGNEW SIGNS - MARK D AGNEW	HOME TOUR STICKERS	60.00
10/11/2024	137702	ALLSTAR TOWING & REPAIR	ALLSTAR TOWING & REPAIR	REPAIR PLUG TIRE CAR 23-10	65.00
			ALLSTAR TOWING & REPAIR	REPAIR PLUG TIRE CAR 22-07	65.00
			ALLSTAR TOWING & REPAIR	OIL CHANGE OPD 18-08	60.00
			ALLSTAR TOWING & REPAIR	TIRE SERVICE OPD 24-09	75.00
					<u>265.00</u>
10/11/2024	137703	AMERICAN SPEEDY PRINTING	AMERICAN SPEEDY PRINTING	MINI GOLF MADNESS MAPS/SCORECARDS	95.00
10/11/2024	137704	AMERICAN TRAINING INSTITUTE	AMERICAN TRAINING INSTITUTE	PALS RENEWAL COURSE ON 05/22/2024 -	380.00
10/11/2024	137705	ATA NATIONAL TITLE	ATA NATIONAL TITLE	UB Receipt Refund for Account #: 214	95.90

Check Date	Check	Vendor Name	Invoice Vendor	Description	Amount
10/11/2024	137706	CASWELL BEVERLY	CASWELL BEVERLY	UB refund for account: 4651500013	324.64
10/11/2024	137707	CORELOGIC CENTRAL REFUNDS	CORELOGIC CENTRAL REFUNDS	2024 Sum Tax Refund 050-601-000-038-	1,295.03
10/11/2024	137708	COUNTYLINE POWER, LLC	COUNTYLINE POWER, LLC	WATER TREATMENT PLANT SCADA UPGRADE	146,236.31
10/11/2024	137709	CUMMINS SALES AND SERVICE	CUMMINS SALES AND SERVICE	REPAIR TOWER 1 - ELECTRONIC CONTROL	7,952.37
10/11/2024	137710	D & D TRUCK & TRAILER PARTS	D & D TRUCK & TRAILER PARTS	FYE6-30-2025 PARTS/SUPPLIES-INDIVIDU	3,827.73
10/11/2024	137711	DONE DEAL COMMERCIAL & RESIDENC	DONE DEAL COMMERCIAL & RESIDENC	CLEANING FOR CURWOOD CASTLE	400.00
10/11/2024	137712	DURAND AUTO PARTS	DURAND AUTO PARTS	ROUTINE PURCHASES NOT TO EXCEED \$20C	173.48
10/11/2024	137713	EMILY OLSON	EMILY OLSON	PARKING FEE REIMBURSEMENT FROM CONFE	90.00
10/11/2024	137714	FALES CHRISTOPHER	FALES CHRISTOPHER	UB refund for account: 3793570022	53.57
10/11/2024	137715	GAME TIME	GAME TIME	TODDLER SWING	277.97
10/11/2024	137716	GOAD AMANDA	GOAD AMANDA	UB refund for account: 2736690002	56.21
10/11/2024	137717	HOME DEPOT CREDIT SERVICES	HOME DEPOT CREDIT SERVICES	SEPTEMBER 2024 PURCHASES	1,586.84
10/11/2024	137718	INDUSTRIAL SUPPLY OF OWOSSO	INDUSTRIAL SUPPLY OF OWOSSO	ROUTINE PURCHASES NOT TO EXCEED \$20C	894.90
10/11/2024	137719	J. RANCK ELECTRIC, INC	J. RANCK ELECTRIC, INC	INSTALLATION OF 26 DOWNTOWN STREET I	172,424.01
10/11/2024	137720	JUDY CRAIG	JUDY CRAIG	MAIL COURIER SERVICE	190.00
10/11/2024	137721	KENT COMMUNICATIONS INC	KENT COMMUNICATIONS INC	SEPTEMBER 30, 2024 UTILITY BILLING W	2,349.60
10/11/2024	137722	KUECHMAN, KYLE	KUECHMAN, KYLE	2024 Sum Tax Refund 050-220-000-067-	9.00
10/11/2024	137723	MODERN CONCRETE	MODERN CONCRETE	CONCRETE PADS FOR DISK GOLF HINTZ WE	770.50
			MODERN CONCRETE	CONCRETE FOR 311 N. CEDAR DRIVEWAY A	476.00
					<u>1,246.50</u>
10/11/2024	137724	NICHOLS PAINTING	NICHOLS PAINTING	PAINT THE BENTLEY PARK PAVILION	6,700.00
10/11/2024	137725	NOVINZIO	NOVINZIO	150 TXS (MIN) @ \$2.35 EACH; \$2.35/TX	352.50
10/11/2024	137726	OWOSSO BOLT & BRASS CO	OWOSSO BOLT & BRASS CO	ROUTINE PURCHASES NOT TO EXCEED \$20C	413.06
10/11/2024	137727	PARK WAREHOUSE LLC	PARK WAREHOUSE LLC	BENCH ALONG THE RIVER NEAR WWTP	963.43
10/11/2024	137728	PLUMMER'S ENVIRONMENTAL SERVICE	PLUMMER'S ENVIRONMENTAL SERVICE	2024 SUMMER SEWER TELEVISIONING PROJECT	999.50
10/11/2024	137729	PROFESSIONAL ANSWERING SERVICE	PROFESSIONAL ANSWERING SERVICE	SERVICE CHARGE	75.00
10/11/2024	137730	RICOH USA	RICOH USA	PRINTING EXPENSES 07/01/2024 - 09/3C	787.64
10/11/2024	137731	ROTARY CLUB OF OWOSSO	ROTARY CLUB OF OWOSSO	MEMBERSHIP DUES/MEALS - AMY FULLER	121.00
10/11/2024	137732	SHIAWASSEE COUNTY HEALTH DEPAR	SHIAWASSEE COUNTY HEALTH DEPAR	PERMIT FEE FOR 2024 STEWART ST. PROJ	47.00
10/11/2024	137733	SHIAWASSEE COUNTY TREASURER	SHIAWASSEE COUNTY TREASURER	2024 TAX COLLECTION 09/16/2024 - 10/	61,907.51
10/11/2024	137734	SHIAWASSEE COUNTY TREASURER	SHIAWASSEE COUNTY TREASURER	MOBILE HOME TAX DISBURSEMENT - SEPT.	452.50
10/11/2024	137735	SLOAN'S SEPTIC TANK SERVICE	SLOAN'S SEPTIC TANK SERVICE	INPORTABLE TOILET CONTRACT - YEAR MAY	1,969.90
			SLOAN'S SEPTIC TANK SERVICE	INPORTABLE TOILET CONTRACT - YEAR MAY	1,719.90
			SLOAN'S SEPTIC TANK SERVICE	INPORTABLE TOILET CONTRACT - YEAR MAY	1,719.90
					<u>5,409.70</u>
10/11/2024	137736	SMITH LAWNSCAPES LLC	SMITH LAWNSCAPES LLC	DOWNTOWN MONTHLY WEEDING JUNE - OCTC	600.00
10/11/2024	137737	STATE OF MICHIGAN	STATE OF MICHIGAN	SOR REGISTRATION FEE SEPT. 2024	30.00
10/11/2024	137738	STATE OF MICHIGAN - DEPARTMENT	STATE OF MICHIGAN - DEPARTMENT	2025 ANNUAL CERTIFICATION FEE FOR AS	350.00
10/11/2024	137739	STONE LILITH ANNE	STONE LILITH ANNE	UB refund for account: 3531070010	42.96
10/11/2024	137740	SUIRE II JOHN	SUIRE II JOHN	UB refund for account: 3915070010	13.98
10/11/2024	137741	SYDNEY WILDING	SYDNEY WILDING	UB REFUND FROM YOUR OLD HOUSE ACCOUN	119.82
10/11/2024	137742	TEAM DESIGN	TEAM DESIGN	ARCHTECTURE SERVICES 114-116 WEST MA	1,500.00
10/11/2024	137743	THE MATTESONS LLC	THE MATTESONS LLC	SOCIAL MEDIA IMAGES - BUSINESS SERIE	300.00
10/11/2024	137744	WAKELAND OIL COMPANY	WAKELAND OIL COMPANY	CAR WASHES FOR OPD JULY 2024 - SEPT.	364.00
10/11/2024	137745	WATKINS TODD	WATKINS TODD	UB refund for account: 5515070003	385.66
10/11/2024	137746	WIN'S ELECTRICAL SUPPLY OF OWC	WIN'S ELECTRICAL SUPPLY OF OWC	FYE6-30-2025 SUPPLIES-INVOICE TO BE	19.98
10/25/2024	137747	ATA NATIONAL TITLE	ATA NATIONAL TITLE	2024 Sum Tax Refund 050-113-001-011-	7.90
10/25/2024	137748	BARTZ EXCAVATING LLC	BARTZ EXCAVATING LLC	SHIAW HEALTH & WELLNESS VALVE REPAIR	3,000.00
10/25/2024	137749	BRAD BARRETT	BRAD BARRETT	MEAL/TRAVEL REIMBURSEMENT	42.88
10/25/2024	137750	BROWN, JULIE ANNE	BROWN, JULIE ANNE	2024 Sum Tax Refund 050-340-003-001-	2.42
10/25/2024	137751	CALEDONIA CHARTER TOWNSHIP	CALEDONIA CHARTER TOWNSHIP	CALDONIA UTILITY FUND PAYMENT QUARTE	50,225.19
10/25/2024	137752	CAPITAL CITY SCUBA INC	CAPITAL CITY SCUBA INC	REFILL/REPAIR SCUBA GEAR	70.00
10/25/2024	137753	CASWELL BEVERLY	CASWELL BEVERLY	UB refund for account: 4651500013	72.16
10/25/2024	137754	CENTRAL MICHIGAN DIESEL, INC.	CENTRAL MICHIGAN DIESEL, INC.	ANNUAL WWTP DUMP TRUCK INSPECTION	414.72
10/25/2024	137755	DAYSTARR COMMUNICATIONS	DAYSTARR COMMUNICATIONS	CASTLE PHONE AND INTERNET - OCTOBER	79.90
10/25/2024	137756	DAYSTARR COMMUNICATIONS	DAYSTARR COMMUNICATIONS	CITY OF OWOSSO PHONE & INTERNET- OCT	1,189.16

Check Date	Check	Vendor Name	Invoice Vendor	Description	Amount
10/25/2024	137757	DELTA DENTAL PLAN OF MICHIGAN	DELTA DENTAL PLAN OF MICHIGAN	DENTAL INSURNACE PREMIUM NOVEMBER	6,378.88
10/25/2024	137758	ELAINE GREENWAY	ELAINE GREENWAY	FOOD/SUPPLIES FOR OHC EVENT	129.83
10/25/2024	137759	FARVER, THOMAS G & CHERYL K	FARVER, THOMAS G & CHERYL K	2024 Sum Tax Refund 050-470-003-004-	70.00
10/25/2024	137760	FOSTER COFFEE COMPANY LLC	FOSTER COFFEE COMPANY LLC	VOLUNTEER APPRECIATION PARTY GIVEAWA	100.00
			FOSTER COFFEE COMPANY LLC	STRATEGIC PLANNING WORKSHOP COFFE	28.00
					<u>128.00</u>
10/25/2024	137761	GLAESER DAWES CORPORATION	GLAESER DAWES CORPORATION	BD Payment Refund	80.00
10/25/2024	137762	GLAESER DAWES CORPORATION	GLAESER DAWES CORPORATION	BD Payment Refund	80.00
10/25/2024	137763	GLAESER DAWES CORPORATION	GLAESER DAWES CORPORATION	BD Payment Refund	80.00
10/25/2024	137764	GLAESER DAWES CORPORATION	GLAESER DAWES CORPORATION	BD Payment Refund	80.00
10/25/2024	137765	H K ALLEN PAPER CO	H K ALLEN PAPER CO	ROUTINE PURCHASES NOT TO EXCEED \$20C	638.00
10/25/2024	137766	HARRIS ELECTRIC LLC	HARRIS ELECTRIC LLC	REPAIR FOR OFD	251.59
10/25/2024	137767	ITSA DELI THING	ITSA DELI THING	BOARD WORKSHOP LUNCH	135.00
10/25/2024	137768	ITSA DELI THING	ITSA DELI THING	VOLUNTEER APPRECIATION PARTY DESSERT	65.00
10/25/2024	137769	J. RANCK ELECTRIC, INC	J. RANCK ELECTRIC, INC	INSTALLATION OF 26 DOWNTOWN STREET I	49,031.72
10/25/2024	137770	JILL DAVIS	JILL DAVIS	STRATEGIC PLANNING WORKSHOP FOOD	125.00
10/25/2024	137771	LAMPHERE PLUMBING & HEATING	INLAMPHERE PLUMBING & HEATING	INSTAFF BATH TOILET NEEDS REPAIR AND S	500.63
			LAMPHERE PLUMBING & HEATING	INSERVICE NEEDED AT OFD	237.00
					<u>737.63</u>
10/25/2024	137772	MATTHEW BRIAN HARVEY	MATTHEW BRIAN HARVEY	MEAL REIMBURSEMENT FOR CONFERENCE	38.14
10/25/2024	137773	MICHIGAN CO INC	MICHIGAN CO INC	SHOP SUPPLY TOWELS	293.14
			MICHIGAN CO INC	SHOP SUPPLY TOWELS	188.26
					<u>481.40</u>
10/25/2024	137774	MILLER KAYLA	MILLER KAYLA	UB refund for account: 1318500012	69.75
10/25/2024	137775	OWOSSO CHARTER TOWNSHIP	OWOSSO CHARTER TOWNSHIP	WATER AGREEMENT QTR ENDING 09/30/202	19,644.99
10/25/2024	137776	OWOSSO COOKIE COMPANY	OWOSSO COOKIE COMPANY	VOLUNTEER APPRECIATION PARTY DESSERT	45.60
10/25/2024	137777	OWOSSO-WATER FUND	OWOSSO-WATER FUND	QUARTERLY WATER BILLS JUNE - SEPT. 2	18,975.76
10/25/2024	137778	P F PETTIBONE & CO	P F PETTIBONE & CO	ORDINANCE BOOK & MINUTES BOOK	518.75
10/25/2024	137779	REMER PLUMBING & HEATING	REMER PLUMBING & HEATING	BD Payment Refund	40.00
10/25/2024	137780	SHATTUCK SPECIALTY ADVERTISING	SHATTUCK SPECIALTY ADVERTISING	BENCH PLATE FOR PARKS - BILL HORTON	12.00
10/25/2024	137781	SHIAWASSEE COUNTY TREASURER	SHIAWASSEE COUNTY TREASURER	2024 TAX COLLECTION 10/02/2024 - 10/	11,472.91
10/25/2024	137782	SHIAWASSEE FAMILY YMCA	SHIAWASSEE FAMILY YMCA	OCTOBER 2024 GYM MEMBERSHIPS	155.55
10/25/2024	137783	SHIAWASSEE HEALTH & WELLNESS	SHIAWASSEE HEALTH & WELLNESS	COSSAP GRANT 15PBJA-21-GG-04538-COAF	3,949.26
10/25/2024	137784	STATE OF MICHIGAN	STATE OF MICHIGAN	SAFE ROUTES TO SCHOOL MDOT COST SHAF	29,938.34
10/25/2024	137785	TODD WYZYNAJTYS	TODD WYZYNAJTYS	STEP STOOL FOR IT	79.97
10/25/2024	137786	TOPPINGS JOSEPH	TOPPINGS JOSEPH	UB refund for account: 2651190009	179.30
10/25/2024	137787	WALTERS MARSHALL	WALTERS MARSHALL	UB refund for account: 3723570004	76.71
10/25/2024	137788	WATER ENVIRONMENT FEDERATION	WATER ENVIRONMENT FEDERATION	MEMBERSHIP RENEWALS FOR TIM GUYSKY 1	170.00
10/25/2024	137789	WILDER STEVE	WILDER STEVE	UB refund for account: 1907000004	68.65
10/25/2024	137790	ZORO TOOLS INC	ZORO TOOLS INC	MAGNETIC BASE DRILL AND LOCTITE REPA	99.39
			ZORO TOOLS INC	MAGNETIC BASE DRILL AND LOCTITE REPA	831.99
			ZORO TOOLS INC	MAGNETIC BASE DRILL AND LOCTITE REPA	383.95
					<u>1,315.33</u>

1 TOTALS:  
 Total of 205 Checks: 4,253,746.51  
 Less 2 Void Checks: 1,166,974.05  
 Total of 203 Disbursements: 3,086,772.46



Warrant 648  
October 17, 2024

Date	Vendor	Description	Fund	Amount
10-17-2024	Gould Law PC	Services Rendered from September 10, 2024 – October 14, 2024	Multiple	\$13,218.40
		Total		<b>\$13,218.40</b>



## MEMORANDUM

---

301 W. MAIN ▪ OWOSSO, MICHIGAN 48867-2958 ▪ WWW.CI.OWOSSO.MI.US

---

**DATE:** November 4, 2024

**TO:** Mayor Teich and the Owosso City Council

**FROM:** City Manager

**SUBJECT:** Donation Agreement – 1921 American LaFrance Firetruck

### Background

The City of Owosso is the owner of a historic 1921 American LaFrance Fire Engine, the City's first gasoline-powered fire truck. The Shiawassee Firefighters Memorial (SFM), a nonprofit organization dedicated to honoring Shiawassee County's fallen firefighters, has been fundraising and planning to establish a public display. The SFM has expressed interest in acquiring the 1921 American LaFrance Fire Engine to include it in this display, which aligns with their nonprofit mission.

The City desires to support the SFM's efforts by donating the Fire Engine to them for this purpose. Under Section 2-348 of the Owosso Ordinance, City Council authorization is required for the disposal or donation of any vehicle that is over seventy (70) years old. Accordingly, Council approval has been sought for this donation.

The attached agreement outlines the terms of the donation, including the transfer of ownership and responsibility for the Fire Engine to SFM, which will use the vehicle for the benefit of the community in creating the display.

### Recommendation

It is recommended that the City Council approve the donation of the 1921 American LaFrance Fire Engine to the Shiawassee Firefighters Memorial. This donation will help preserve the City's history while supporting the SFM in its mission to honor local firefighters. The donation agreement has been reviewed and outlines the necessary legal considerations, including the transfer of ownership and the City's lack of ongoing obligations for the vehicle's maintenance.

Approval of this donation aligns with the City's goals of supporting community initiatives and honoring the history of Owosso's public safety services.

**RESOLUTION NO.**

**RESOLUTION AUTHORIZING THE DONATION OF THE 1921 AMERICAN LAFRANCE  
FIRE ENGINE TO THE SHIAWASSEE FIREFIGHTERS MEMORIAL**

WHEREAS, the City of Owosso is the owner of a 1921 American LaFrance Fire Engine, the City's first gasoline-powered fire truck (hereinafter referred to as "Fire Engine"); and

WHEREAS, the Shiawassee Firefighters Memorial, a Michigan nonprofit organization, has been raising funds and planning to create a public display to honor Shiawassee County's fallen firefighters; and

WHEREAS, the City of Owosso desires to donate the Fire Engine to the Shiawassee Firefighters Memorial to support its mission of honoring local firefighters and preserving the history of public safety in the community; and

WHEREAS, Section 2-348 of the Owosso City Code requires City Council authorization for the disposal or donation of any vehicle over seventy (70) years old, including the Fire Engine; and

WHEREAS, the donation agreement between the City of Owosso and the Shiawassee Firefighters Memorial outlines the terms of the donation, including the transfer of ownership and responsibility for the Fire Engine.

NOW, THEREFORE, BE IT RESOLVED by the City Council of the City of Owosso, Shiawassee County, Michigan that:

- FIRST: The Owosso City Council hereby approves the donation of the 1921 LaFrance Fire Engine to the Shiawassee Firefighters Memorial, subject to the terms outlined in the donation agreement.
- SECOND: The Mayor and City Clerk are hereby authorized and directed to execute the donation agreement on behalf of the City of Owosso, and to take any and all actions necessary to complete the donation.
- THIRD: Upon execution of the agreement, ownership and all responsibilities associated with the 1921 American LaFrance Fire Engine shall be transferred to the Shiawassee Firefighters Memorial.
- FOURTH: The City of Owosso makes no representations or warranties regarding the condition of the Fire Engine and disclaims any implied warranties, including fitness for a particular purpose.
- FIFTH: The donation is made with the understanding that the Fire Engine will be used in furtherance of the Shiawassee Firefighters Memorial's nonprofit mission and displayed as a tribute to Shiawassee County's fallen firefighters.

## **AGREEMENT FOR DONATION OF 1921 LAFRANCE FIRE ENGINE**

This Agreement ("Agreement") is made and entered into on this 4th day of November, 2024, by and between the **City of Owosso**, a Michigan municipal corporation, located at 301 W. Main Street, Owosso, Michigan 48867 (hereinafter referred to as "City"), and the **Shiawassee Firefighters Memorial**, a Michigan domestic nonprofit corporation, ID #802260237, with its address at P.O. Box 1606, Owosso, Michigan 48867 (hereinafter referred to as "SFM").

**WHEREAS**, the City is the owner of a 1921 LaFrance Fire Engine, its first gasoline-powered fire truck (hereinafter referred to as "Fire Engine"); and

**WHEREAS**, SFM has been raising funds and planning to create a public display to honor Shiawassee County's fallen firefighters; and

**WHEREAS**, the City desires to donate the Fire Engine to SFM to assist in its mission of honoring local firefighters; and

**WHEREAS**, SFM agrees to accept the Fire Engine as a donation from the City for the purpose of creating the display and to use the Fire Engine for the benefit of the community in accordance with its nonprofit mission; and

**WHEREAS**, pursuant to Section 2-348 of the City of Owosso Ordinance, the disposal or sale of any vehicle seventy (70) years or older, including works of art, decorative objects, or the like, requires City Council authorization; and the City Council has duly authorized the donation of the Fire Engine as surplus material.

**NOW, THEREFORE**, in consideration of the mutual promises and agreements contained herein, the parties agree as follows:

**1. Donation of the Fire Engine:**

The City hereby agrees to donate to SFM the 1921 LaFrance Fire Engine in its current "as-is" condition.

**2. Purpose:**

SFM agrees that the donation of the Fire Engine is made for the purpose of creating a display to honor Shiawassee County's fallen firefighters and to be used in furtherance of SFM's nonprofit mission.

**3. Ownership Transfer:**

Upon execution of this Agreement, ownership of the Fire Engine shall transfer from the City to SFM, and SFM shall assume all responsibility and liability associated with the Fire Engine.

**4. Display and Maintenance:**

SFM agrees to use its best efforts to create and maintain the display honoring Shiawassee County's firefighters, including care and preservation of the Fire Engine. The City shall have no obligation to fund or maintain the display.

**5. No Warranties:**

The City makes no representations or warranties regarding the condition of the Fire Engine and disclaims any implied warranties, including fitness for a particular purpose.

**6. Indemnification:**

SFM agrees to indemnify, defend, and hold harmless the City, its officers, employees, and agents from any and all claims, damages, liabilities, or expenses arising out of or related to SFM's possession, use, or display of the Fire Engine.

**7. Governing Law:**

This Agreement shall be governed by and construed in accordance with the laws of the State of Michigan.

**8. Entire Agreement:**

This Agreement constitutes the entire agreement between the parties and supersedes all prior negotiations, understandings, and agreements related to the donation of the Fire Engine.

**IN WITNESS WHEREOF**, the parties hereto have executed this Agreement as of the date first above written.

**CITY OF OWOSSO**

By: \_\_\_\_\_

Robert J. Teich Jr., Mayor

Date: \_\_\_\_\_

By: \_\_\_\_\_

Amy K. Kirkland, City Clerk

Date: \_\_\_\_\_

**SHIAWASSEE FIREFIGHTERS MEMORIAL**

By: \_\_\_\_\_

Travis Schneider, President

Date: \_\_\_\_\_





## MEMORANDUM

---

301 W. MAIN ▪ OWOSSO, MICHIGAN 48867-2958 ▪ WWW.CI.OWOSSO.MI.US

---

DATE: October 28, 2024  
TO: Owosso City Council  
FROM: Brad Barrett, Finance Director  
SUBJECT: Monthly Financial Report – September 2024

RECOMMENDATION:

Receive and file communication from Finance Department.

BACKGROUND:

Per Section 8.6(c) of the Owosso City Charter....

*During each month, the City Manager shall submit to the Council data showing the relation between the estimated and actual revenues and expenditures to the end of the preceding month;....*

A revenue and expenditure report and cash summary report is included for the period ending September 30, 2024.

Revenue Expense Report

The column labeled "Activity for month" reflects revenues received and expenses paid during the specific month and the column labeled "YTD Balance reflects revenues received and expenses paid since the beginning of the fiscal year (July 1<sup>st</sup>.)

FISCAL IMPACTS:

None.

**Document originated by:**

Revenue and Expenditure Report for City of Owosso – Period ending 09-30-2024  
Cash Summary by Account for City of Owosso – 09-01-2024– 09-30-2024

PERIOD ENDING 09/30/2024

\*NOTE: Available Balance / Pct Budget Used does not reflect amounts encumbered.

CITY OF OWOSSO  
MONTHLY REVENUE AND EXPENDITURE REPORT

GL NUMBER	DESCRIPTION	2024-25		ACTIVITY FOR MONTH 09/30/24 INCR (DECR)	YTD BALANCE 09/30/2024 NORM (ABNORM)	AVAILABLE BALANCE NORM (ABNORM)	% BDGT USED
		ORIGINAL BUDGET	2024-25 AMENDED BUDGET				
Fund 101 - GENERAL FUND							
Revenues							
101-000-402.000	GENERAL PROPERTY TAX	3,968,376.00	3,968,376.00	2,712,670.54	3,522,680.17	445,695.83	88.77
101-000-402.500	OBSOLETE PROPERTY REHAB TAXES (O	3,306.00	3,306.00	0.00	0.00	3,306.00	0.00
101-000-404.000	PA 298 OF 1917	316,083.00	316,083.00	215,944.52	280,426.62	35,656.38	88.72
101-000-432.000	PAYMENT IN LIEU OF TAXES (PILT)	5,000.00	5,000.00	0.00	0.00	5,000.00	0.00
101-000-434.000	TRAILER PARK TAXES	1,000.00	1,000.00	543.00	634.50	365.50	63.45
101-000-437.000	INDUSTRIAL/COMMERCIAL FACILITIE	14,045.00	14,045.00	0.00	0.00	14,045.00	0.00
101-000-439.000	MARIJUANA TAX DISTR.	237,851.00	237,851.00	0.00	0.00	237,851.00	0.00
101-000-445.000	INTEREST & PENALTIES ON TAXES	19,858.00	19,858.00	1,779.84	1,957.10	17,900.90	9.86
101-000-447.000	ADMINISTRATION FEES	162,835.00	162,835.00	59,411.88	82,517.25	80,317.75	50.68
101-000-476.000	LIQUOR LICENSES	10,500.00	10,500.00	0.00	4,214.10	6,285.90	40.13
101-000-477.000	CABLE TELEVISION FRANCHISE FEES	73,000.00	73,000.00	0.00	0.00	73,000.00	0.00
101-000-478.000	ROW LICENSES	1,000.00	1,000.00	100.00	200.00	800.00	20.00
101-000-491.000	PERMITS (GUN)	400.00	400.00	30.00	100.00	300.00	25.00
101-000-502.000	GRANT-FEDERAL	173,570.00	173,570.00	0.00	0.00	173,570.00	0.00
101-000-502.100-COSSAP2022	FEDERAL GRANT - DEPT OF JUSTICE	100,000.00	100,000.00	4,714.77	8,520.03	91,479.97	8.52
101-000-540.000	STATE SOURCES	3,750.00	3,750.00	0.00	0.00	3,750.00	0.00
101-000-540.000-DDASTRLITE	STATE SOURCES	300,000.00	300,000.00	0.00	0.00	300,000.00	0.00
101-000-540.000-MCOLES-CPE	STATE SOURCES	0.00	0.00	1,650.00	1,650.00	(1,650.00)	100.00
101-000-573.000	LOCAL COMMUNITY STABILIZATION S	150,000.00	150,000.00	0.00	0.00	150,000.00	0.00
101-000-574.000	REVENUE SHARING	1,619,621.00	1,619,621.00	0.00	0.00	1,619,621.00	0.00
101-000-574.050	REVENUE SHARING - STATUTORY	521,375.00	521,375.00	0.00	0.00	521,375.00	0.00
101-000-605.200	CHARGE FOR SERVICES RENDERED	17,500.00	17,500.00	1,134.19	7,991.34	9,508.66	45.66
101-000-605.250	DUPLICATING SERVICES	1,000.00	1,000.00	35.69	186.74	813.26	18.67
101-000-605.300	FIRE SERVICES	5,000.00	5,000.00	1,000.00	3,000.00	2,000.00	60.00
101-000-605.301	POLICE DEPARTMENT SERVICES	195,764.00	195,764.00	21,125.01	21,125.01	174,638.99	10.79
101-000-605.336	AMBULANCE SERVICES - TWP	331,898.00	331,898.00	0.00	236,600.13	95,297.87	71.29
101-000-607.100	FILING FEES - ABATEMENT APPLICA'	800.00	800.00	0.00	800.00	0.00	100.00
101-000-638.000	AMBULANCE CHARGES	291,515.00	291,515.00	32,141.04	113,131.89	178,383.11	38.81
101-000-638.000-TREAT-ONLY	AMBULANCE CHARGES	13,883.00	13,883.00	350.00	1,400.00	12,483.00	10.08
101-000-638.100	AMBULANCE MILEAGE CHARGES	196,461.00	196,461.00	11,884.32	31,454.70	165,006.30	16.01
101-000-638.200	AMBULANCE/ ADVANCED LIFE SUPPOR'	432,847.00	432,847.00	60,403.46	166,882.52	265,964.48	38.55
101-000-642.000	CHARGE FOR SERVICES - SALES	2,500.00	2,500.00	255.00	1,230.00	1,270.00	49.20
101-000-652.200	PARKING LEASE INCOME	1,680.00	1,680.00	0.00	0.00	1,680.00	0.00
101-000-657.000	ORDINANCE FINES & COSTS	10,000.00	10,000.00	644.49	2,798.06	7,201.94	27.98
101-000-657.100	PARKING VIOLATIONS	7,500.00	7,500.00	250.00	835.00	6,665.00	11.13
101-000-665.000	INTEREST INCOME	50,000.00	50,000.00	37,851.73	90,690.91	(40,690.91)	181.38
101-000-665.100	MERS INTEREST INCOME	100.00	100.00	47.79	48.71	51.29	48.71
101-000-667.100	RENTAL INCOME	500.00	500.00	30.00	30.00	470.00	6.00
101-000-673.000	SALE OF FIXED ASSETS	0.00	0.00	0.00	250,855.50	(250,855.50)	100.00
101-000-675.000	MISCELLANEOUS	75,000.00	75,000.00	890.31	3,388.33	71,611.67	4.52
101-000-676.200	WASTEWATER UTIL. ADMIN REIMB	185,623.00	185,623.00	33,285.16	33,285.16	152,337.84	17.93
101-000-676.254	FUND 254 ADMIN CHARGE BACK	5,500.00	5,500.00	0.00	110.80	5,389.20	2.01
101-000-676.300	CITY UTILITIES ADMIN REIMB	452,627.00	452,627.00	111,301.46	111,301.46	341,325.54	24.59
101-000-676.400	DDA TIF CHARGE BACK	134,024.00	134,024.00	1,242.36	1,242.36	132,781.64	0.93
101-000-676.500	ACT 51 ADMIN REIMBURSEMENT	209,887.00	209,887.00	19,854.53	19,854.53	190,032.47	9.46
101-000-676.600	BRA ADMIN FEES	6,451.00	6,451.00	0.00	0.00	6,451.00	0.00
101-000-687.000	INSURANCE REFUNDS/REBATES	88,000.00	88,000.00	0.00	0.00	88,000.00	0.00
101-000-696.000	BOND PROCEEDS	806,371.00	806,371.00	0.00	0.00	806,371.00	0.00
101-000-699.287	ARPA TRANSFER IN	276,000.00	276,000.00	0.00	0.00	276,000.00	0.00

PERIOD ENDING 09/30/2024

\*NOTE: Available Balance / Pct Budget Used does not reflect amounts encumbered.

CITY OF OWOSSO  
 MONTHLY REVENUE AND EXPENDITURE REPORT

GL NUMBER	DESCRIPTION	2024-25	2024-25	ACTIVITY FOR	YTD BALANCE	AVAILABLE	% BDGT USED
		ORIGINAL BUDGET	AMENDED BUDGET	MONTH 09/30/24 INCR (DECR)	09/30/2024 NORM (ABNORM)	BALANCE NORM (ABNORM)	
Fund 101 - GENERAL FUND							
Revenues							
TOTAL REVENUES		11,480,001.00	11,480,001.00	3,330,571.09	5,001,142.92	6,478,858.08	43.56
Expenditures							
101	CITY COUNCIL	8,060.00	8,060.00	128.00	1,633.37	6,426.63	20.27
171	CITY MANAGER	339,400.00	339,400.00	24,601.49	69,273.16	270,126.84	20.41
201	FINANCE	254,052.00	254,052.00	19,263.54	51,494.92	202,557.08	20.27
210	CITY ATTORNEY	164,600.00	164,600.00	8,908.87	31,996.91	132,603.09	19.44
215	CLERK	254,983.00	254,983.00	17,899.09	50,279.54	204,703.46	19.72
228	INFORMATION & TECHNOLOGY	154,000.00	154,000.00	21,880.14	64,128.93	89,871.07	41.64
253	TREASURY	275,205.00	275,205.00	16,798.15	49,202.91	226,002.09	17.88
257	ASSESSING	222,748.00	222,748.00	15,973.89	44,870.41	177,877.59	20.14
261	GENERAL ADMIN	448,621.00	448,621.00	31,923.84	257,217.62	191,403.38	57.34
262	ELECTION	79,829.00	79,829.00	8,341.58	31,023.45	48,805.55	38.86
265	BUILDING & GROUNDS	835,789.00	835,789.00	10,105.47	25,494.39	810,294.61	3.05
270	HUMAN RESOURCES	217,410.00	217,410.00	15,783.18	43,976.44	173,433.56	20.23
301	POLICE	3,105,516.00	3,105,516.00	211,298.36	602,675.49	2,502,840.51	19.41
336	FIRE	4,053,099.00	4,053,099.00	207,454.50	513,418.76	3,539,680.24	12.67
371	BUILDING AND SAFETY	46,045.00	46,045.00	0.00	511.68	45,533.32	1.11
441	PUBLIC WORKS	1,262,732.00	1,262,732.00	107,638.95	481,849.54	780,882.46	38.16
528	LEAF AND BRUSH COLLECTION	313,011.00	313,011.00	22,217.94	56,361.53	256,649.47	18.01
585	PARKING	36,025.00	36,025.00	1,348.86	3,273.15	32,751.85	9.09
720	COMMUNITY DEVELOPMENT	37,222.00	37,222.00	3,569.54	10,607.97	26,614.03	28.50
751	PARKS	369,923.00	369,923.00	34,970.11	95,480.77	274,442.23	25.81
966	TRANSFERS OUT	52,633.00	52,633.00	11,915.11	11,915.11	40,717.89	22.64
TOTAL EXPENDITURES		12,530,903.00	12,530,903.00	792,020.61	2,496,686.05	10,034,216.95	19.92
Fund 101 - GENERAL FUND:							
TOTAL REVENUES		11,480,001.00	11,480,001.00	3,330,571.09	5,001,142.92	6,478,858.08	43.56
TOTAL EXPENDITURES		12,530,903.00	12,530,903.00	792,020.61	2,496,686.05	10,034,216.95	19.92
NET OF REVENUES & EXPENDITURES		(1,050,902.00)	(1,050,902.00)	2,538,550.48	2,504,456.87	(3,555,358.87)	238.31

PERIOD ENDING 09/30/2024

\*NOTE: Available Balance / Pct Budget Used does not reflect amounts encumbered.

CITY OF OWOSSO  
 MONTHLY REVENUE AND EXPENDITURE REPORT

GL NUMBER	DESCRIPTION	2024-25	2024-25	ACTIVITY FOR	YTD BALANCE	AVAILABLE	% BDGT USED
		ORIGINAL BUDGET	AMENDED BUDGET	MONTH 09/30/24 INCR (DECR)	09/30/2024 NORM (ABNORM)	BALANCE NORM (ABNORM)	
Fund 202 - MAJOR STREET FUND							
Revenues							
202-000-502.000	GRANT-FEDERAL	560,000.00	560,000.00	0.00	284,852.57	275,147.43	50.87
202-000-502.000-SRTS2024GR	GRANT-FEDERAL	0.00	0.00	0.00	52,787.45	(52,787.45)	100.00
202-000-540.000	STATE SOURCES	22,500.00	22,500.00	0.00	0.00	22,500.00	0.00
202-000-540.000-MDOT-TRAIL	STATE SOURCES	225,000.00	225,000.00	14,792.00	14,792.00	210,208.00	6.57
202-000-541.000	TRUNKLINE MAINTENANCE	42,948.00	42,948.00	0.00	0.00	42,948.00	0.00
202-000-542.000	GAS & WEIGHT TAX	1,534,024.00	1,534,024.00	145,093.06	145,093.06	1,388,930.94	9.46
202-000-665.000	INTEREST INCOME	10,000.00	10,000.00	25,096.88	66,849.32	(56,849.32)	668.49
202-000-675.000	MISCELLANEOUS	0.00	0.00	0.00	3,486.15	(3,486.15)	100.00
202-000-678.000	SPECIAL ASSESSMENT	0.00	0.00	9,763.87	10,659.42	(10,659.42)	100.00
TOTAL REVENUES		2,394,472.00	2,394,472.00	194,745.81	578,519.97	1,815,952.03	24.16
Expenditures							
451	CONSTRUCTION	1,587,350.00	1,587,350.00	238,254.25	568,807.03	1,018,542.97	35.83
463	STREET MAINTENANCE	690,735.00	690,735.00	101,363.85	181,357.71	509,377.29	26.26
473	BRIDGE MAINTENANCE	85,100.00	85,100.00	0.00	0.00	85,100.00	0.00
474	TRAFFIC SERVICES-MAINTENANCE	16,655.00	16,655.00	407.13	758.89	15,896.11	4.56
478	SNOW & ICE CONTROL	171,045.00	171,045.00	3,428.23	9,201.63	161,843.37	5.38
480	TREE TRIMMING	86,396.00	86,396.00	2,992.49	7,129.81	79,266.19	8.25
482	ADMINISTRATION & ENGINEERING	219,407.00	219,407.00	19,125.85	27,528.38	191,878.62	12.55
485	LOCAL STREET TRANSFER	350,000.00	350,000.00	0.00	0.00	350,000.00	0.00
490	TRUNKLINE TREE TRIM & REMOVAL	0.00	0.00	0.00	106.02	(106.02)	100.00
491	TRUNKLINE STORM DRAIN, CURBS	0.00	0.00	0.00	207.43	(207.43)	100.00
494	TRUNKLINE TRAFFIC SIGNS	0.00	0.00	52.00	208.57	(208.57)	100.00
497	TRUNKLINE SNOW & ICE CONTROL	12,784.00	12,784.00	0.00	0.00	12,784.00	0.00
TOTAL EXPENDITURES		3,219,472.00	3,219,472.00	365,623.80	795,305.47	2,424,166.53	24.70
Fund 202 - MAJOR STREET FUND:							
TOTAL REVENUES		2,394,472.00	2,394,472.00	194,745.81	578,519.97	1,815,952.03	24.16
TOTAL EXPENDITURES		3,219,472.00	3,219,472.00	365,623.80	795,305.47	2,424,166.53	24.70
NET OF REVENUES & EXPENDITURES		(825,000.00)	(825,000.00)	(170,877.99)	(216,785.50)	(608,214.50)	26.28

REVENUE AND EXPENDITURE REPORT FOR CITY OF OWOSSO  
 PERIOD ENDING 09/30/2024

\*NOTE: Available Balance / Pct Budget Used does not reflect amounts encumbered.

CITY OF OWOSSO  
 MONTHLY REVENUE AND EXPENDITURE REPORT

GL NUMBER	DESCRIPTION	2024-25		ACTIVITY FOR MONTH 09/30/24 INCR (DECR)	YTD BALANCE 09/30/2024 NORM (ABNORM)	AVAILABLE		% BDGT USED
		ORIGINAL BUDGET	2024-25 AMENDED BUDGET			BALANCE NORM (ABNORM)	BALANCE NORM (ABNORM)	
Fund 203 - LOCAL STREET FUND								
Revenues								
203-000-502.000	GRANT-FEDERAL	175,000.00	175,000.00	0.00	0.00	175,000.00	0.00	
203-000-502.000-SRTS2024GR	GRANT-FEDERAL	0.00	0.00	0.00	52,787.45	(52,787.45)	100.00	
203-000-540.000	STATE SOURCES	43,500.00	43,500.00	0.00	0.00	43,500.00	0.00	
203-000-542.000	GAS & WEIGHT TAX	564,856.00	564,856.00	53,452.20	53,452.20	511,403.80	9.46	
203-000-665.000	INTEREST INCOME	10,000.00	10,000.00	5,031.58	11,013.41	(1,013.41)	110.13	
203-000-678.000	SPECIAL ASSESSMENT	0.00	0.00	2,597.42	7,925.86	(7,925.86)	100.00	
203-000-699.202	MAJOR STREET TRANSFER	350,000.00	350,000.00	0.00	0.00	350,000.00	0.00	
TOTAL REVENUES		1,143,356.00	1,143,356.00	61,081.20	125,178.92	1,018,177.08	10.95	
Expenditures								
451	CONSTRUCTION	307,350.00	307,350.00	41.88	41.88	307,308.12	0.01	
463	STREET MAINTENANCE	716,373.00	716,373.00	96,543.78	183,823.40	532,549.60	25.66	
474	TRAFFIC SERVICES-MAINTENANCE	1,500.00	1,500.00	46.10	842.30	657.70	56.15	
478	SNOW & ICE CONTROL	79,256.00	79,256.00	1,523.64	4,089.35	75,166.65	5.16	
480	TREE TRIMMING	126,409.00	126,409.00	13,503.81	20,412.82	105,996.18	16.15	
482	ADMINISTRATION & ENGINEERING	122,490.00	122,490.00	9,961.28	18,363.14	104,126.86	14.99	
TOTAL EXPENDITURES		1,353,378.00	1,353,378.00	121,620.49	227,572.89	1,125,805.11	16.82	
Fund 203 - LOCAL STREET FUND:								
TOTAL REVENUES		1,143,356.00	1,143,356.00	61,081.20	125,178.92	1,018,177.08	10.95	
TOTAL EXPENDITURES		1,353,378.00	1,353,378.00	121,620.49	227,572.89	1,125,805.11	16.82	
NET OF REVENUES & EXPENDITURES		(210,022.00)	(210,022.00)	(60,539.29)	(102,393.97)	(107,628.03)	48.75	

REVENUE AND EXPENDITURE REPORT FOR CITY OF OWOSSO  
 PERIOD ENDING 09/30/2024

\*NOTE: Available Balance / Pct Budget Used does not reflect amounts encumbered.

CITY OF OWOSSO  
 MONTHLY REVENUE AND EXPENDITURE REPORT

GL NUMBER	DESCRIPTION	2024-25		ACTIVITY FOR MONTH 09/30/24 INCR (DECR)	YTD BALANCE 09/30/2024 NORM (ABNORM)	AVAILABLE BALANCE NORM (ABNORM)	% BDGT USED
		ORIGINAL BUDGET	2024-25 AMENDED BUDGET				
Fund 208 - PARK/RECREATION SITES FUND							
Revenues							
208-000-665.000	INTEREST INCOME	500.00	500.00	184.46	487.19	12.81	97.44
208-000-674.100	PRIVATE DONATIONS	8,000.00	8,000.00	8,000.00	11,650.00	(3,650.00)	145.63
TOTAL REVENUES		8,500.00	8,500.00	8,184.46	12,137.19	(3,637.19)	142.79
Expenditures							
751	PARKS	31,700.00	31,700.00	1,125.00	12,545.57	19,154.43	39.58
TOTAL EXPENDITURES		31,700.00	31,700.00	1,125.00	12,545.57	19,154.43	39.58
Fund 208 - PARK/RECREATION SITES FUND:							
TOTAL REVENUES		8,500.00	8,500.00	8,184.46	12,137.19	(3,637.19)	142.79
TOTAL EXPENDITURES		31,700.00	31,700.00	1,125.00	12,545.57	19,154.43	39.58
NET OF REVENUES & EXPENDITURES		(23,200.00)	(23,200.00)	7,059.46	(408.38)	(22,791.62)	1.76

REVENUE AND EXPENDITURE REPORT FOR CITY OF OWOSSO  
 PERIOD ENDING 09/30/2024

\*NOTE: Available Balance / Pct Budget Used does not reflect amounts encumbered.

CITY OF OWOSSO  
 MONTHLY REVENUE AND EXPENDITURE REPORT

GL NUMBER	DESCRIPTION	2024-25		ACTIVITY FOR MONTH 09/30/24 INCR (DECR)	YTD BALANCE 09/30/2024 NORM (ABNORM)	AVAILABLE		% BDGT USED
		ORIGINAL BUDGET	2024-25 AMENDED BUDGET			BALANCE NORM (ABNORM)	BALANCE NORM (ABNORM)	
Fund 239 - OMS/DDA REVLG LOAN FUND								
Revenues								
239-000-644.000	PENALTIES - LATE CHARGES	250.00	250.00	0.00	29.08		220.92	11.63
239-000-665.000	INTEREST INCOME	10,000.00	10,000.00	2,895.70	5,726.12		4,273.88	57.26
239-000-670.000	LOAN PRINCIPAL	0.00	0.00	(10,643.89)	0.00		0.00	0.00
239-000-670.100	LOAN INTEREST	15,000.00	15,000.00	897.47	2,741.42		12,258.58	18.28
TOTAL REVENUES		25,250.00	25,250.00	(6,850.72)	8,496.62		16,753.38	33.65
Expenditures								
200	GEN SERVICES	2,814.00	2,814.00	0.00	550.00		2,264.00	19.55
TOTAL EXPENDITURES		2,814.00	2,814.00	0.00	550.00		2,264.00	19.55
Fund 239 - OMS/DDA REVLG LOAN FUND :								
TOTAL REVENUES		25,250.00	25,250.00	(6,850.72)	8,496.62		16,753.38	33.65
TOTAL EXPENDITURES		2,814.00	2,814.00	0.00	550.00		2,264.00	19.55
NET OF REVENUES & EXPENDITURES		22,436.00	22,436.00	(6,850.72)	7,946.62		14,489.38	35.42

PERIOD ENDING 09/30/2024

\*NOTE: Available Balance / Pct Budget Used does not reflect amounts encumbered.

CITY OF OWOSSO  
 MONTHLY REVENUE AND EXPENDITURE REPORT

GL NUMBER	DESCRIPTION	2024-25		ACTIVITY FOR MONTH 09/30/24 INCR (DECR)	YTD BALANCE 09/30/2024 NORM (ABNORM)	AVAILABLE		% BDGT USED
		ORIGINAL BUDGET	2024-25 AMENDED BUDGET			BALANCE NORM (ABNORM)	BALANCE NORM (ABNORM)	
Fund 243 - BRA / OBRA #12 WOODWARD LOFT								
Revenues								
243-000-402.300	OBRA:TAX CAPTURE	135,052.00	135,052.00	0.00	0.00	135,052.00		0.00
243-000-402.300-BRA-DIST22	OBRA:TAX CAPTURE	16.00	16.00	0.00	0.00	16.00		0.00
243-000-665.000	INTEREST INCOME	50.00	50.00	8.41	26.95	23.05		53.90
TOTAL REVENUES		135,118.00	135,118.00	8.41	26.95	135,091.05		0.02
Expenditures								
721	PROFESSIONAL SERVICES	1,003.00	1,003.00	0.00	0.00	1,003.00		0.00
964	TAX REIMBURSEMENTS	134,065.00	134,065.00	0.00	0.00	134,065.00		0.00
TOTAL EXPENDITURES		135,068.00	135,068.00	0.00	0.00	135,068.00		0.00
Fund 243 - BRA / OBRA #12 WOODWARD LOFT:								
TOTAL REVENUES		135,118.00	135,118.00	8.41	26.95	135,091.05		0.02
TOTAL EXPENDITURES		135,068.00	135,068.00	0.00	0.00	135,068.00		0.00
NET OF REVENUES & EXPENDITURES		50.00	50.00	8.41	26.95	23.05		53.90



PERIOD ENDING 09/30/2024

\*NOTE: Available Balance / Pct Budget Used does not reflect amounts encumbered.

CITY OF OWOSSO  
 MONTHLY REVENUE AND EXPENDITURE REPORT

GL NUMBER	DESCRIPTION	2024-25		ACTIVITY FOR MONTH 09/30/24 INCR (DECR)	YTD BALANCE 09/30/2024 NORM (ABNORM)	AVAILABLE BALANCE NORM (ABNORM)	% BDGT USED
		ORIGINAL BUDGET	2024-25 AMENDED BUDGET				
Fund 248 - DOWNTOWN DEVELOPMENT AUTHORITY							
Revenues							
248-000-402.000	GENERAL PROPERTY TAX	38,963.00	38,963.00	17,645.14	24,847.28	14,115.72	63.77
248-000-402.100	TIF	234,378.00	234,378.00	0.00	0.00	234,378.00	0.00
248-000-573.000	LOCAL COMMUNITY STABILIZATION S	21,478.00	21,478.00	0.00	0.00	21,478.00	0.00
248-000-665.000	INTEREST INCOME	5,000.00	5,000.00	613.48	1,687.25	3,312.75	33.75
248-000-670.100	LOAN INTEREST	1,577.00	1,577.00	133.52	406.21	1,170.79	25.76
248-000-674.400	INCOME-PROMOTION	15,000.00	15,000.00	683.00	1,843.00	13,157.00	12.29
248-000-674.600	INCOME-DESIGN	0.00	0.00	360.00	360.00	(360.00)	100.00
248-000-674.700	EV STATION REVENUE	2,400.00	2,400.00	385.44	1,023.89	1,376.11	42.66
248-000-699.101	TRANSFERS FROM GENERAL FUND	35,133.00	35,133.00	7,540.11	7,540.11	27,592.89	21.46
TOTAL REVENUES		353,929.00	353,929.00	27,360.69	37,707.74	316,221.26	10.65
Expenditures							
200	GEN SERVICES	240,104.00	240,104.00	3,680.36	13,352.60	226,751.40	5.56
261	GENERAL ADMIN	89,179.00	89,179.00	6,800.17	18,850.29	70,328.71	21.14
704	ORGANIZATION	750.00	750.00	17.96	17.96	732.04	2.39
705	PROMOTION	15,050.00	15,050.00	548.23	1,521.23	13,528.77	10.11
706	DESIGN	7,000.00	7,000.00	1,030.84	1,060.84	5,939.16	15.15
707	ECONOMIC VITALITY	1,500.00	1,500.00	75.00	225.00	1,275.00	15.00
TOTAL EXPENDITURES		353,583.00	353,583.00	12,152.56	35,027.92	318,555.08	9.91
Fund 248 - DOWNTOWN DEVELOPMENT AUTHORITY:							
TOTAL REVENUES		353,929.00	353,929.00	27,360.69	37,707.74	316,221.26	10.65
TOTAL EXPENDITURES		353,583.00	353,583.00	12,152.56	35,027.92	318,555.08	9.91
NET OF REVENUES & EXPENDITURES		346.00	346.00	15,208.13	2,679.82	(2,333.82)	774.51

PERIOD ENDING 09/30/2024

\*NOTE: Available Balance / Pct Budget Used does not reflect amounts encumbered.

CITY OF OWOSSO  
 MONTHLY REVENUE AND EXPENDITURE REPORT

GL NUMBER	DESCRIPTION	2024-25		ACTIVITY FOR MONTH 09/30/24 INCR (DECR)	YTD BALANCE 09/30/2024 NORM (ABNORM)	AVAILABLE BALANCE NORM (ABNORM)	% BGD USED
		ORIGINAL BUDGET	2024-25 AMENDED BUDGET				
Fund 249 - BUILDING INSPECTION FUND							
Revenues							
249-000-476.100	MARIJUANA LICENSE FEE	55,000.00	55,000.00	10,000.00	25,000.00	30,000.00	45.45
249-000-490.000	PERMITS-BUILDING	105,000.00	105,000.00	13,337.80	30,416.00	74,584.00	28.97
249-000-490.100	PERMITS-ELECTRICAL	30,000.00	30,000.00	2,665.00	13,735.00	16,265.00	45.78
249-000-490.200	PERMITS-PLUMBING & MECHANICAL	55,000.00	55,000.00	5,520.00	20,070.00	34,930.00	36.49
249-000-628.000	RENTAL REGISTRATION	9,000.00	9,000.00	0.00	900.00	8,100.00	10.00
249-000-665.000	INTEREST INCOME	5,000.00	5,000.00	935.49	2,470.02	2,529.98	49.40
TOTAL REVENUES		259,000.00	259,000.00	32,458.29	92,591.02	166,408.98	35.75
Expenditures							
200	GEN SERVICES	100,506.00	100,506.00	6,353.61	20,612.44	79,893.56	20.51
371	BUILDING AND SAFETY	161,834.00	161,834.00	12,251.63	24,603.85	137,230.15	15.20
TOTAL EXPENDITURES		262,340.00	262,340.00	18,605.24	45,216.29	217,123.71	17.24
Fund 249 - BUILDING INSPECTION FUND:							
TOTAL REVENUES		259,000.00	259,000.00	32,458.29	92,591.02	166,408.98	35.75
TOTAL EXPENDITURES		262,340.00	262,340.00	18,605.24	45,216.29	217,123.71	17.24
NET OF REVENUES & EXPENDITURES		(3,340.00)	(3,340.00)	13,853.05	47,374.73	(50,714.73)	1,418.41

PERIOD ENDING 09/30/2024

\*NOTE: Available Balance / Pct Budget Used does not reflect amounts encumbered.

CITY OF OWOSSO  
 MONTHLY REVENUE AND EXPENDITURE REPORT

GL NUMBER	DESCRIPTION	2024-25		ACTIVITY FOR MONTH 09/30/24 INCR (DECR)	YTD BALANCE 09/30/2024 NORM (ABNORM)	AVAILABLE BALANCE NORM (ABNORM)	% BDGT USED
		ORIGINAL BUDGET	2024-25 AMENDED BUDGET				
Fund 254 - HOUSING & REDEVELOPMENT							
Revenues							
254-000-540.000-114116MAIN	STATE SOURCES	0.00	0.00	417.00	(16,365.97)	16,365.97	100.00
254-000-540.000-MSHDANEP24	STATE SOURCES	72,500.00	72,500.00	0.00	22,771.80	49,728.20	31.41
254-000-540.000-MSHDMIHOPE	STATE SOURCES	53,000.00	53,000.00	0.00	29,624.25	23,375.75	55.89
254-000-665.000	INTEREST INCOME	0.00	0.00	232.55	613.75	(613.75)	100.00
254-000-675.000-114116MAIN	MISCELLANEOUS	0.00	0.00	0.00	(12,660.84)	12,660.84	100.00
TOTAL REVENUES		125,500.00	125,500.00	649.55	23,982.99	101,517.01	19.11
Expenditures							
200	GEN SERVICES	125,500.00	125,500.00	417.00	23,560.95	101,939.05	18.77
TOTAL EXPENDITURES		125,500.00	125,500.00	417.00	23,560.95	101,939.05	18.77
Fund 254 - HOUSING & REDEVELOPMENT:							
TOTAL REVENUES		125,500.00	125,500.00	649.55	23,982.99	101,517.01	19.11
TOTAL EXPENDITURES		125,500.00	125,500.00	417.00	23,560.95	101,939.05	18.77
NET OF REVENUES & EXPENDITURES		0.00	0.00	232.55	422.04	(422.04)	100.00



REVENUE AND EXPENDITURE REPORT FOR CITY OF OWOSSO  
 PERIOD ENDING 09/30/2024

\*NOTE: Available Balance / Pct Budget Used does not reflect amounts encumbered.

CITY OF OWOSSO  
 MONTHLY REVENUE AND EXPENDITURE REPORT

GL NUMBER	DESCRIPTION	2024-25		ACTIVITY FOR MONTH 09/30/24 INCR (DECR)	YTD BALANCE 09/30/2024 NORM (ABNORM)	AVAILABLE		% BDGT USED
		ORIGINAL BUDGET	2024-25 AMENDED BUDGET			BALANCE NORM (ABNORM)	BALANCE NORM (ABNORM)	
Fund 272 - OBRA FUND-DISTRICT #17 CARGILL (PREV #8)								
Revenues								
272-000-402.300	OBRA:TAX CAPTURE	209,874.00	209,874.00	0.00	0.00	209,874.00		0.00
TOTAL REVENUES		209,874.00	209,874.00	0.00	0.00	209,874.00		0.00
Expenditures								
721	PROFESSIONAL SERVICES	12,050.00	12,050.00	0.00	0.00	12,050.00		0.00
905	DEBT SERVICE	167,999.00	167,999.00	0.00	0.00	167,999.00		0.00
TOTAL EXPENDITURES		180,049.00	180,049.00	0.00	0.00	180,049.00		0.00
<hr/>								
Fund 272 - OBRA FUND-DISTRICT #17 CARGILL (PREV #8):								
TOTAL REVENUES		209,874.00	209,874.00	0.00	0.00	209,874.00		0.00
TOTAL EXPENDITURES		180,049.00	180,049.00	0.00	0.00	180,049.00		0.00
NET OF REVENUES & EXPENDITURES		29,825.00	29,825.00	0.00	0.00	29,825.00		0.00

REVENUE AND EXPENDITURE REPORT FOR CITY OF OWOSSO  
 PERIOD ENDING 09/30/2024

\*NOTE: Available Balance / Pct Budget Used does not reflect amounts encumbered.

CITY OF OWOSSO  
 MONTHLY REVENUE AND EXPENDITURE REPORT

GL NUMBER	DESCRIPTION	2024-25		ACTIVITY FOR MONTH 09/30/24 INCR (DECR)	YTD BALANCE 09/30/2024 NORM (ABNORM)	AVAILABLE		% BDGT USED
		ORIGINAL BUDGET	2024-25 AMENDED BUDGET			BALANCE NORM (ABNORM)	BALANCE NORM (ABNORM)	
Fund 273 - OBRA #9 ROBBINS LOFT								
Revenues								
273-000-402.300	OBRA:TAX CAPTURE	4,878.00	4,878.00	0.00	0.00	4,878.00	0.00	
273-000-665.000	INTEREST INCOME	1,000.00	1,000.00	220.27	707.20	292.80	70.72	
TOTAL REVENUES		5,878.00	5,878.00	220.27	707.20	5,170.80	12.03	
Expenditures								
721	PROFESSIONAL SERVICES	1,200.00	1,200.00	0.00	0.00	1,200.00	0.00	
964	TAX REIMBURSEMENTS	3,678.00	3,678.00	0.00	0.00	3,678.00	0.00	
TOTAL EXPENDITURES		4,878.00	4,878.00	0.00	0.00	4,878.00	0.00	
Fund 273 - OBRA #9 ROBBINS LOFT:								
TOTAL REVENUES		5,878.00	5,878.00	220.27	707.20	5,170.80	12.03	
TOTAL EXPENDITURES		4,878.00	4,878.00	0.00	0.00	4,878.00	0.00	
NET OF REVENUES & EXPENDITURES		1,000.00	1,000.00	220.27	707.20	292.80	70.72	

REVENUE AND EXPENDITURE REPORT FOR CITY OF OWOSSO  
 PERIOD ENDING 09/30/2024

\*NOTE: Available Balance / Pct Budget Used does not reflect amounts encumbered.

CITY OF OWOSSO  
 MONTHLY REVENUE AND EXPENDITURE REPORT

GL NUMBER	DESCRIPTION	2024-25		ACTIVITY FOR MONTH 09/30/24 INCR (DECR)	YTD BALANCE 09/30/2024 NORM (ABNORM)	AVAILABLE		% BDGT USED
		ORIGINAL BUDGET	2024-25 AMENDED BUDGET			BALANCE NORM (ABNORM)	BALANCE NORM (ABNORM)	
Fund 276 - OBRA FUND DISTRICT #16 - QDOBA								
Revenues								
276-000-402.300	OBRA:TAX CAPTURE	12,253.00	12,253.00	0.00	0.00	12,253.00	0.00	0.00
276-000-674.200	DONATIONS	17,623.00	17,623.00	0.00	0.00	17,623.00	0.00	0.00
TOTAL REVENUES		29,876.00	29,876.00	0.00	0.00	29,876.00	0.00	
Expenditures								
721	PROFESSIONAL SERVICES	1,704.00	1,704.00	0.00	612.50	1,091.50	35.94	
905	DEBT SERVICE	28,172.00	28,172.00	0.00	0.00	28,172.00	0.00	
TOTAL EXPENDITURES		29,876.00	29,876.00	0.00	612.50	29,263.50	2.05	
Fund 276 - OBRA FUND DISTRICT #16 - QDOBA:								
TOTAL REVENUES		29,876.00	29,876.00	0.00	0.00	29,876.00	0.00	
TOTAL EXPENDITURES		29,876.00	29,876.00	0.00	612.50	29,263.50	2.05	
NET OF REVENUES & EXPENDITURES		0.00	0.00	0.00	(612.50)	612.50	100.00	





PERIOD ENDING 09/30/2024

\*NOTE: Available Balance / Pct Budget Used does not reflect amounts encumbered.

CITY OF OWOSSO  
 MONTHLY REVENUE AND EXPENDITURE REPORT

GL NUMBER	DESCRIPTION	2024-25	2024-25	ACTIVITY FOR	YTD BALANCE	AVAILABLE	% BDGT USED
		ORIGINAL BUDGET	AMENDED BUDGET	MONTH 09/30/24 INCR (DECR)	09/30/2024 NORM (ABNORM)	BALANCE NORM (ABNORM)	
Fund 283 - OBRA FUND-DISTRICT#3-TIAL							
Revenues							
283-000-402.300	OBRA:TAX CAPTURE	16,824.00	16,824.00	0.00	0.00	16,824.00	0.00
TOTAL REVENUES		16,824.00	16,824.00	0.00	0.00	16,824.00	0.00
Expenditures							
721	PROFESSIONAL SERVICES	750.00	750.00	0.00	0.00	750.00	0.00
905	DEBT SERVICE	19,391.00	19,391.00	0.00	0.00	19,391.00	0.00
TOTAL EXPENDITURES		20,141.00	20,141.00	0.00	0.00	20,141.00	0.00
<hr/>							
Fund 283 - OBRA FUND-DISTRICT#3-TIAL:							
TOTAL REVENUES		16,824.00	16,824.00	0.00	0.00	16,824.00	0.00
TOTAL EXPENDITURES		20,141.00	20,141.00	0.00	0.00	20,141.00	0.00
NET OF REVENUES & EXPENDITURES		(3,317.00)	(3,317.00)	0.00	0.00	(3,317.00)	0.00

PERIOD ENDING 09/30/2024

\*NOTE: Available Balance / Pct Budget Used does not reflect amounts encumbered.

CITY OF OWOSSO  
 MONTHLY REVENUE AND EXPENDITURE REPORT

GL NUMBER	DESCRIPTION	2024-25		ACTIVITY FOR MONTH 09/30/24 INCR (DECR)	YTD BALANCE 09/30/2024		AVAILABLE BALANCE		% BGD USED
		ORIGINAL BUDGET	2024-25 AMENDED BUDGET		NORM	(ABNORM)	NORM	(ABNORM)	
Fund 284 - OPIOID SETTLEMENT FUND									
Revenues									
284-000-665.000	INTEREST INCOME	100.00	100.00	152.22	401.85		(301.85)	401.85	
284-000-685.000	OPIOID SETTLEMENT REVENUE	0.00	0.00	2,146.25	11,647.26		(11,647.26)	100.00	
TOTAL REVENUES		<u>100.00</u>	<u>100.00</u>	<u>2,298.47</u>	<u>12,049.11</u>		<u>(11,949.11)</u>	<u>2,049.11</u>	
Fund 284 - OPIOID SETTLEMENT FUND:									
TOTAL REVENUES		100.00	100.00	2,298.47	12,049.11		(11,949.11)	2,049.11	
TOTAL EXPENDITURES		0.00	0.00	0.00	0.00		0.00	0.00	
NET OF REVENUES & EXPENDITURES		<u>100.00</u>	<u>100.00</u>	<u>2,298.47</u>	<u>12,049.11</u>		<u>(11,949.11)</u>	<u>2,049.11</u>	

REVENUE AND EXPENDITURE REPORT FOR CITY OF OWOSSO  
 PERIOD ENDING 09/30/2024

\*NOTE: Available Balance / Pct Budget Used does not reflect amounts encumbered.

CITY OF OWOSSO  
 MONTHLY REVENUE AND EXPENDITURE REPORT

GL NUMBER	DESCRIPTION	2024-25		ACTIVITY FOR MONTH 09/30/24 INCR (DECR)	YTD BALANCE 09/30/2024 NORM (ABNORM)	AVAILABLE		% BDGT USED
		ORIGINAL BUDGET	2024-25 AMENDED BUDGET			BALANCE	BALANCE	
Fund 287 - ARPA - AMERICAN RESCUE PLAN ACT								
Revenues								
287-000-528.000	OTHER FEDERAL GRANTS	0.00	0.00	0.00	138,351.75	(138,351.75)		100.00
287-000-665.000	INTEREST INCOME	20,000.00	20,000.00	1,753.04	7,401.32	12,598.68		37.01
TOTAL REVENUES		20,000.00	20,000.00	1,753.04	145,753.07	(125,753.07)		728.77
Expenditures								
966	TRANSFERS OUT	1,413,573.00	1,413,573.00	16,155.38	166,973.43	1,246,599.57		11.81
TOTAL EXPENDITURES		1,413,573.00	1,413,573.00	16,155.38	166,973.43	1,246,599.57		11.81
Fund 287 - ARPA - AMERICAN RESCUE PLAN ACT:								
TOTAL REVENUES		20,000.00	20,000.00	1,753.04	145,753.07	(125,753.07)		728.77
TOTAL EXPENDITURES		1,413,573.00	1,413,573.00	16,155.38	166,973.43	1,246,599.57		11.81
NET OF REVENUES & EXPENDITURES		(1,393,573.00)	(1,393,573.00)	(14,402.34)	(21,220.36)	(1,372,352.64)		1.52

PERIOD ENDING 09/30/2024

\*NOTE: Available Balance / Pct Budget Used does not reflect amounts encumbered.

CITY OF OWOSSO  
 MONTHLY REVENUE AND EXPENDITURE REPORT

GL NUMBER	DESCRIPTION	2024-25		ACTIVITY FOR MONTH 09/30/24 INCR (DECR)	YTD BALANCE 09/30/2024 NORM (ABNORM)	AVAILABLE		% BDGT USED
		ORIGINAL BUDGET	2024-25 AMENDED BUDGET			BALANCE NORM (ABNORM)	BALANCE NORM (ABNORM)	
Fund 297 - HISTORICAL FUND								
Revenues								
297-000-643.000	SALES	3,000.00	3,000.00	269.00	1,261.00	1,739.00		42.03
297-000-665.000	INTEREST INCOME	2,000.00	2,000.00	314.47	830.47	1,169.53		41.52
297-000-665.100	ENDOWMENT SPENDABLE FUNDS	1,066.00	1,066.00	0.00	0.00	1,066.00		0.00
297-000-667.100	RENTAL INCOME	2,800.00	2,800.00	0.00	0.00	2,800.00		0.00
297-000-674.100	PRIVATE DONATIONS	20,000.00	20,000.00	1,800.00	5,799.00	14,201.00		29.00
297-000-674.200	DONATIONS	11,650.00	11,650.00	4,320.66	4,620.66	7,029.34		39.66
297-000-675.000	MISCELLANEOUS	0.00	0.00	90.00	927.11	(927.11)		100.00
297-000-699.101	TRASFERS FROM GENERAL FUND	17,500.00	17,500.00	4,375.00	4,375.00	13,125.00		25.00
TOTAL REVENUES		58,016.00	58,016.00	11,169.13	17,813.24	40,202.76		30.70
Expenditures								
797	HISTORICAL COMMISSION	30,598.00	30,598.00	2,990.46	6,965.79	23,632.21		22.77
798	CASTLE	14,806.00	14,806.00	776.27	2,835.23	11,970.77		19.15
799	GOULD HOUSE	10,329.00	10,329.00	0.00	16,685.65	(6,356.65)		161.54
800	COMSTOCK/WOODARD	2,000.00	2,000.00	0.00	107.76	1,892.24		5.39
TOTAL EXPENDITURES		57,733.00	57,733.00	3,766.73	26,594.43	31,138.57		46.06
Fund 297 - HISTORICAL FUND:								
TOTAL REVENUES		58,016.00	58,016.00	11,169.13	17,813.24	40,202.76		30.70
TOTAL EXPENDITURES		57,733.00	57,733.00	3,766.73	26,594.43	31,138.57		46.06
NET OF REVENUES & EXPENDITURES		283.00	283.00	7,402.40	(8,781.19)	9,064.19		3,102.89

PERIOD ENDING 09/30/2024

\*NOTE: Available Balance / Pct Budget Used does not reflect amounts encumbered.

CITY OF OWOSSO  
MONTHLY REVENUE AND EXPENDITURE REPORT

GL NUMBER	DESCRIPTION	2024-25		ACTIVITY FOR MONTH 09/30/24 INCR (DECR)	YTD BALANCE 09/30/2024 NORM (ABNORM)	AVAILABLE		% BDGT USED
		ORIGINAL BUDGET	2024-25 AMENDED BUDGET			BALANCE NORM (ABNORM)	BALANCE NORM (ABNORM)	
Fund 301 - GENERAL DEBT SERVICE (VOTED BONDS)								
Revenues								
301-000-402.000	GENERAL PROPERTY TAX	723,150.00	723,150.00	462,631.10	641,619.99	81,530.01		88.73
301-000-573.000	LOCAL COMMUNITY STABILIZATION S	50,000.00	50,000.00	0.00	0.00	50,000.00		0.00
TOTAL REVENUES		<u>773,150.00</u>	<u>773,150.00</u>	<u>462,631.10</u>	<u>641,619.99</u>	<u>131,530.01</u>		<u>82.99</u>
Expenditures								
905	DEBT SERVICE	773,150.00	773,150.00	0.00	0.00	773,150.00		0.00
TOTAL EXPENDITURES		<u>773,150.00</u>	<u>773,150.00</u>	<u>0.00</u>	<u>0.00</u>	<u>773,150.00</u>		<u>0.00</u>
Fund 301 - GENERAL DEBT SERVICE (VOTED BONDS):								
TOTAL REVENUES		<u>773,150.00</u>	<u>773,150.00</u>	<u>462,631.10</u>	<u>641,619.99</u>	<u>131,530.01</u>		<u>82.99</u>
TOTAL EXPENDITURES		<u>773,150.00</u>	<u>773,150.00</u>	<u>0.00</u>	<u>0.00</u>	<u>773,150.00</u>		<u>0.00</u>
NET OF REVENUES & EXPENDITURES		<u>0.00</u>	<u>0.00</u>	<u>462,631.10</u>	<u>641,619.99</u>	<u>(641,619.99)</u>		<u>100.00</u>

REVENUE AND EXPENDITURE REPORT FOR CITY OF OWOSSO  
 PERIOD ENDING 09/30/2024

\*NOTE: Available Balance / Pct Budget Used does not reflect amounts encumbered.

CITY OF OWOSSO  
 MONTHLY REVENUE AND EXPENDITURE REPORT

GL NUMBER	DESCRIPTION	2024-25	2024-25	ACTIVITY FOR	YTD BALANCE	AVAILABLE	% BDGT USED
		ORIGINAL BUDGET	AMENDED BUDGET	MONTH 09/30/24 INCR (DECR)	09/30/2024 NORM (ABNORM)	BALANCE NORM (ABNORM)	
Fund 588 - TRANSPORTATION FUND							
Revenues							
588-000-402.000	GENERAL PROPERTY TAX	104,307.00	104,307.00	71,205.41	92,468.53	11,838.47	88.65
588-000-573.000	LOCAL COMMUNITY STABILIZATION S	1,581.00	1,581.00	0.00	0.00	1,581.00	0.00
588-000-665.000	INTEREST INCOME	0.00	0.00	7.83	25.23	(25.23)	100.00
TOTAL REVENUES		<u>105,888.00</u>	<u>105,888.00</u>	<u>71,213.24</u>	<u>92,493.76</u>	<u>13,394.24</u>	<u>87.35</u>
Expenditures							
200	GEN SERVICES	105,888.00	105,888.00	105,073.83	105,073.83	814.17	99.23
TOTAL EXPENDITURES		<u>105,888.00</u>	<u>105,888.00</u>	<u>105,073.83</u>	<u>105,073.83</u>	<u>814.17</u>	<u>99.23</u>
Fund 588 - TRANSPORTATION FUND:							
TOTAL REVENUES		105,888.00	105,888.00	71,213.24	92,493.76	13,394.24	87.35
TOTAL EXPENDITURES		105,888.00	105,888.00	105,073.83	105,073.83	814.17	99.23
NET OF REVENUES & EXPENDITURES		0.00	0.00	(33,860.59)	(12,580.07)	12,580.07	100.00

PERIOD ENDING 09/30/2024

\*NOTE: Available Balance / Pct Budget Used does not reflect amounts encumbered.

CITY OF OWOSSO  
 MONTHLY REVENUE AND EXPENDITURE REPORT

GL NUMBER	DESCRIPTION	2024-25		ACTIVITY FOR MONTH 09/30/24 INCR (DECR)	YTD BALANCE 09/30/2024 NORM (ABNORM)	AVAILABLE BALANCE NORM (ABNORM)	% BDGT USED
		ORIGINAL BUDGET	2024-25 AMENDED BUDGET				
Fund 590 - SEWER FUND							
Revenues							
590-000-491.000	PERMITS	1,000.00	1,000.00	150.00	300.00	700.00	30.00
590-000-643.100	METERED SALES	3,325,992.00	3,325,992.00	783,633.43	750,909.93	2,575,082.07	22.58
590-000-644.000	PENALTIES - LATE CHARGES	43,238.00	43,238.00	79.23	19,259.58	23,978.42	44.54
590-000-665.000	INTEREST INCOME	10,000.00	10,000.00	9,798.28	23,271.39	(13,271.39)	232.71
590-000-675.000	MISCELLANEOUS	5,000.00	5,000.00	0.00	0.00	5,000.00	0.00
TOTAL REVENUES		3,385,230.00	3,385,230.00	793,660.94	793,740.90	2,591,489.10	23.45
Expenditures							
200	GEN SERVICES	2,628,755.00	2,628,755.00	237,383.84	639,921.24	1,988,833.76	24.34
549	SEWER OPERATIONS	307,880.00	307,880.00	9,613.86	111,234.25	196,645.75	36.13
901	CAPITAL OUTLAY	427,500.00	427,500.00	667.07	1,006.67	426,493.33	0.24
905	DEBT SERVICE	124,302.00	124,302.00	62,401.47	62,401.47	61,900.53	50.20
TOTAL EXPENDITURES		3,488,437.00	3,488,437.00	310,066.24	814,563.63	2,673,873.37	23.35
Fund 590 - SEWER FUND:							
TOTAL REVENUES		3,385,230.00	3,385,230.00	793,660.94	793,740.90	2,591,489.10	23.45
TOTAL EXPENDITURES		3,488,437.00	3,488,437.00	310,066.24	814,563.63	2,673,873.37	23.35
NET OF REVENUES & EXPENDITURES		(103,207.00)	(103,207.00)	483,594.70	(20,822.73)	(82,384.27)	20.18

PERIOD ENDING 09/30/2024

\*NOTE: Available Balance / Pct Budget Used does not reflect amounts encumbered.

CITY OF OWOSSO  
 MONTHLY REVENUE AND EXPENDITURE REPORT

GL NUMBER	DESCRIPTION	2024-25	2024-25	ACTIVITY FOR	YTD BALANCE	AVAILABLE	% BDGT USED
		ORIGINAL BUDGET	AMENDED BUDGET	MONTH 09/30/24 INCR (DECR)	09/30/2024 NORM (ABNORM)	BALANCE NORM (ABNORM)	
Fund 591 - WATER FUND							
Revenues							
591-000-491.000	PERMITS	1,500.00	1,500.00	100.00	350.00	1,150.00	23.33
591-000-493.000	PERMITS-OWOSSO TOWNSHIP	10,000.00	10,000.00	0.00	0.00	10,000.00	0.00
591-000-502.000-DWRLF24-25	GRANT-FEDERAL	1,745,000.00	1,745,000.00	420,991.12	497,591.12	1,247,408.88	28.52
591-000-538.000-DWRF755501	CAPITAL CONTRIBUTION-FEDERAL	500,000.00	500,000.00	0.00	0.00	500,000.00	0.00
591-000-538.000-DWRLF23-24	CAPITAL CONTRIBUTION-FEDERAL	617,634.00	617,634.00	0.00	0.00	617,634.00	0.00
591-000-538.000-DWRLF24-25	CAPITAL CONTRIBUTION-FEDERAL	1,745,000.00	1,745,000.00	0.00	0.00	1,745,000.00	0.00
591-000-605.100	WATER MAIN REPLACEMENT CHARGE	794,937.00	794,937.00	201,820.09	202,196.22	592,740.78	25.44
591-000-605.350	MATERIAL & SERVICE	35,000.00	35,000.00	(2,329.26)	32,905.92	2,094.08	94.02
591-000-607.200	WATER AND SEWER FEES	0.00	0.00	0.00	43,910.00	(43,910.00)	100.00
591-000-643.100	METERED SALES	3,732,072.00	3,732,072.00	993,589.95	962,207.16	2,769,864.84	25.78
591-000-643.200	METERED SALES-WHOLESALE-USAGE	339,900.00	339,900.00	26,019.72	80,626.87	259,273.13	23.72
591-000-644.000	PENALTIES - LATE CHARGES	67,905.00	67,905.00	154.62	21,639.04	46,265.96	31.87
591-000-665.000	INTEREST INCOME	10,000.00	10,000.00	22,093.39	57,794.10	(47,794.10)	577.94
591-000-667.100	RENTAL INCOME	1,320.00	1,320.00	120.00	360.00	960.00	27.27
591-000-667.300	HYDRANT RENTAL	33,000.00	33,000.00	(162.00)	2,088.00	30,912.00	6.33
591-000-670.100	LOAN INTEREST	1,929.00	1,929.00	0.00	74.12	1,854.88	3.84
591-000-673.000	SALE OF FIXED ASSETS	0.00	0.00	0.00	929.08	(929.08)	100.00
591-000-675.000	MISCELLANEOUS	0.00	0.00	0.00	281.77	(281.77)	100.00
591-000-675.200	UB FEES	2,000.00	2,000.00	340.00	1,530.00	470.00	76.50
591-000-699.287	ARPA TRANSFER IN	1,137,573.00	1,137,573.00	16,155.38	166,973.43	970,599.57	14.68
TOTAL REVENUES		10,774,770.00	10,774,770.00	1,678,893.01	2,071,456.83	8,703,313.17	19.23
Expenditures							
200	GEN SERVICES	895,857.00	895,857.00	79,275.72	113,706.23	782,150.77	12.69
552	WATER UNDERGROUND	2,042,741.00	2,042,741.00	96,029.39	482,417.32	1,560,323.68	23.62
553	WATER FILTRATION	1,878,385.00	1,878,385.00	97,668.14	241,106.18	1,637,278.82	12.84
901	CAPITAL OUTLAY	6,559,421.00	6,559,421.00	304,482.94	714,777.08	5,844,643.92	10.90
905	DEBT SERVICE	600,489.00	600,489.00	184,247.01	184,247.01	416,241.99	30.68
TOTAL EXPENDITURES		11,976,893.00	11,976,893.00	761,703.20	1,736,253.82	10,240,639.18	14.50
Fund 591 - WATER FUND:							
TOTAL REVENUES		10,774,770.00	10,774,770.00	1,678,893.01	2,071,456.83	8,703,313.17	19.23
TOTAL EXPENDITURES		11,976,893.00	11,976,893.00	761,703.20	1,736,253.82	10,240,639.18	14.50
NET OF REVENUES & EXPENDITURES		(1,202,123.00)	(1,202,123.00)	917,189.81	335,203.01	(1,537,326.01)	27.88



PERIOD ENDING 09/30/2024

\*NOTE: Available Balance / Pct Budget Used does not reflect amounts encumbered.

CITY OF OWOSSO  
 MONTHLY REVENUE AND EXPENDITURE REPORT

GL NUMBER	DESCRIPTION	2024-25	2024-25	ACTIVITY FOR	YTD BALANCE	AVAILABLE	% BGDG USED
		ORIGINAL BUDGET	AMENDED BUDGET	MONTH 09/30/24 INCR (DECR)	09/30/2024 NORM (ABNORM)	BALANCE NORM (ABNORM)	
Fund 599 - WASTEWATER FUND							
Revenues							
599-000-538.000-CWSRF23-24	CAPITAL CONTRIBUTION-FEDERAL (B	0.00	0.00	844,692.52	844,692.52	(844,692.52)	100.00
599-000-538.000-CWSRF24-25	CAPITAL CONTRIBUTION-FEDERAL (B	0.00	0.00	0.00	47,370.00	(47,370.00)	100.00
599-000-540.000-CWSRF24-25	STATE SOURCES (GRANT)	2,600,000.00	2,600,000.00	0.00	0.00	2,600,000.00	0.00
599-000-602.100	OP & MAINT CHRG - OWOSSO	1,407,517.00	1,407,517.00	118,566.15	358,857.71	1,048,659.29	25.50
599-000-602.200	OP & MAINT CHRG - OWOSSO TWP	230,729.00	230,729.00	18,836.60	59,235.22	171,493.78	25.67
599-000-602.300	OP & MAINT CHRG - CALEDONIA TWS	139,084.00	139,084.00	11,424.15	32,084.40	106,999.60	23.07
599-000-602.400	OP & MAINT CHRG - CORUNNA	264,539.00	264,539.00	21,327.11	60,954.69	203,584.31	23.04
599-000-603.100	REPLACEMENT CHRG - OWOSSO	265,554.00	265,554.00	22,309.44	67,280.22	198,273.78	25.34
599-000-603.200	REPLACEMENT CHRG - OWOSSO TWP	59,624.00	59,624.00	4,913.38	15,125.43	44,498.57	25.37
599-000-603.300	REPLACEMENT CHRG - CALEDONIA TW	40,136.00	40,136.00	3,321.17	9,654.18	30,481.82	24.05
599-000-603.400	REPLACEMENT CHRG - CORUNNA	48,954.00	48,954.00	3,978.01	11,506.16	37,447.84	23.50
599-000-606.100	DEBT SERVICE CHRG - OWOSSO	563,996.00	563,996.00	46,999.87	140,999.61	422,996.39	25.00
599-000-606.200	DEBT SERVICE CHRG - OWOSSO TWP.	228,791.00	228,791.00	19,065.99	57,197.97	171,593.03	25.00
599-000-606.300	DEBT SERVICE CHRG - CALEDONIA T	173,455.00	173,455.00	14,454.68	43,364.04	130,090.96	25.00
599-000-606.400	DEBT SERVICE CHRG - CORUNNA	97,901.00	97,901.00	8,158.47	24,475.41	73,425.59	25.00
599-000-665.000	INTEREST INCOME	10,000.00	10,000.00	10,847.02	22,419.74	(12,419.74)	224.20
599-000-675.000	MISCELLANEOUS	5,000.00	5,000.00	1,394.45	3,997.71	1,002.29	79.95
TOTAL REVENUES		6,135,280.00	6,135,280.00	1,150,289.01	1,799,215.01	4,336,064.99	29.33
Expenditures							
200	GEN SERVICES	34,700.00	34,700.00	1,950.05	5,421.33	29,278.67	15.62
548	WASTEWATER OPERATIONS	2,007,153.00	2,007,153.00	169,039.53	360,715.51	1,646,437.49	17.97
901	CAPITAL OUTLAY	3,581,400.00	3,581,400.00	762,939.94	1,676,099.10	1,905,300.90	46.80
905	DEBT SERVICE	1,064,144.00	1,064,144.00	161,056.72	161,056.72	903,087.28	15.13
TOTAL EXPENDITURES		6,687,397.00	6,687,397.00	1,094,986.24	2,203,292.66	4,484,104.34	32.95
Fund 599 - WASTEWATER FUND:							
TOTAL REVENUES		6,135,280.00	6,135,280.00	1,150,289.01	1,799,215.01	4,336,064.99	29.33
TOTAL EXPENDITURES		6,687,397.00	6,687,397.00	1,094,986.24	2,203,292.66	4,484,104.34	32.95
NET OF REVENUES & EXPENDITURES		(552,117.00)	(552,117.00)	55,302.77	(404,077.65)	(148,039.35)	73.19

\*NOTE: Available Balance / Pct Budget Used does not reflect amounts encumbered.

CITY OF OWOSSO  
 MONTHLY REVENUE AND EXPENDITURE REPORT

GL NUMBER	DESCRIPTION	2024-25		ACTIVITY FOR MONTH 09/30/24 INCR (DECR)	YTD BALANCE 09/30/2024 NORM (ABNORM)	AVAILABLE		% BGD USED
		ORIGINAL BUDGET	2024-25 AMENDED BUDGET			BALANCE NORM (ABNORM)	BALANCE NORM (ABNORM)	
Fund 661 - FLEET MAINTENANCE FUND								
Revenues								
661-000-665.000	INTEREST INCOME	50,000.00	50,000.00	12,486.43	33,782.53	16,217.47		67.57
661-000-667.200	EQUIPMENT RENTAL	859,648.00	859,648.00	82,424.67	230,089.38	629,558.62		26.77
661-000-675.000	MISCELLANEOUS	0.00	0.00	0.00	275.00	(275.00)		100.00
TOTAL REVENUES		<u>909,648.00</u>	<u>909,648.00</u>	<u>94,911.10</u>	<u>264,146.91</u>	<u>645,501.09</u>		<u>29.04</u>
Expenditures								
594	FLEET MAINTENANCE	474,411.00	474,411.00	45,064.67	86,625.74	387,785.26		18.26
901	CAPITAL OUTLAY	710,000.00	710,000.00	0.00	17,925.00	692,075.00		2.52
TOTAL EXPENDITURES		<u>1,184,411.00</u>	<u>1,184,411.00</u>	<u>45,064.67</u>	<u>104,550.74</u>	<u>1,079,860.26</u>		<u>8.83</u>
Fund 661 - FLEET MAINTENANCE FUND:								
TOTAL REVENUES		909,648.00	909,648.00	94,911.10	264,146.91	645,501.09		29.04
TOTAL EXPENDITURES		<u>1,184,411.00</u>	<u>1,184,411.00</u>	<u>45,064.67</u>	<u>104,550.74</u>	<u>1,079,860.26</u>		<u>8.83</u>
NET OF REVENUES & EXPENDITURES		(274,763.00)	(274,763.00)	49,846.43	159,596.17	(434,359.17)		58.09
TOTAL REVENUES - ALL FUNDS		38,452,515.00	38,452,515.00	7,915,248.09	11,718,780.34	26,733,734.66		30.48
TOTAL EXPENDITURES - ALL FUNDS		<u>44,040,039.00</u>	<u>44,040,039.00</u>	<u>3,648,380.99</u>	<u>8,794,380.18</u>	<u>35,245,658.82</u>		<u>19.97</u>
NET OF REVENUES & EXPENDITURES		(5,587,524.00)	(5,587,524.00)	4,266,867.10	2,924,400.16	(8,511,924.16)		52.34

CASH SUMMARY BY ACCOUNT FOR CITY OF OWOSSO  
 FROM 09/01/2024 TO 09/30/2024  
 FUND: ALL FUNDS  
 CASH AND INVESTMENT ACCOUNTS

Fund Account	Description	Beginning Balance 09/01/2024	Total Debits	Total Credits	Ending Balance 09/30/2024
Fund 101	GENERAL FUND				
001.200	POOLED CASH (HUNTINGTON BANK)	38,882.29	3,222,238.18	781,719.57	2,479,400.90
001.204	HUNTINGTON LIQUIDITY PORTAL	421,689.22	2,409.55	0.00	424,098.77
001.205	THE STATE BANK	2,733,728.89	9,903.53	0.00	2,743,632.42
001.206	SWEEP ACCOUNT HUNTINGTON	82,142.98	8,216.87	0.00	90,359.85
001.300	FRANKENMUTH CREDIT UNION ACCOUNTS	1,714,189.69	8,554.86	0.00	1,722,744.55
001.306	DORT FEDERAL CREDIT UNION ACCOUNTS	1,620,861.23	8,711.91	0.00	1,629,573.14
002.203	AMBULANCE PAYMENT BANK ACCOUNT	217,856.79	80,202.87	26.10	298,033.56
004.000	PETTY CASH	1,725.00	0.00	0.00	1,725.00
005.401	MERS DC FUNDS - RESTRICTED	3,341.81	21,191.72	24,065.84	467.69
	GENERAL FUND	6,834,417.90	3,361,429.49	805,811.51	9,390,035.88
Fund 202	MAJOR STREET FUND				
001.200	POOLED CASH (HUNTINGTON BANK)	33,696.96	154,856.93	365,623.80	(177,069.91)
001.201	MI CLASS ACCOUNT	1,208,577.04	5,196.13	0.00	1,213,773.17
001.204	HUNTINGTON LIQUIDITY PORTAL	3,017,603.59	17,241.59	0.00	3,034,845.18
001.300	FRANKENMUTH CREDIT UNION ACCOUNTS	532,839.62	2,659.16	0.00	535,498.78
	MAJOR STREET FUND	4,792,717.21	179,953.81	365,623.80	4,607,047.22
Fund 203	LOCAL STREET FUND				
001.200	POOLED CASH (HUNTINGTON BANK)	196,597.98	56,049.62	121,620.49	131,027.11
001.201	MI CLASS ACCOUNT	42,268.48	181.68	0.00	42,450.16
001.204	HUNTINGTON LIQUIDITY PORTAL	383,438.65	2,190.74	0.00	385,629.39
001.300	FRANKENMUTH CREDIT UNION ACCOUNTS	532,839.62	2,659.16	0.00	535,498.78
	LOCAL STREET FUND	1,155,144.73	61,081.20	121,620.49	1,094,605.44
Fund 208	PARK/RECREATION SITES FUND				
001.200	POOLED CASH (HUNTINGTON BANK)	(15,634.10)	8,000.00	1,125.00	(8,759.10)
001.204	HUNTINGTON LIQUIDITY PORTAL	32,286.04	184.46	0.00	32,470.50
	PARK/RECREATION SITES FUND	16,651.94	8,184.46	1,125.00	23,711.40
Fund 239	OMS/DDA REVLG LOAN FUND				
001.200	POOLED CASH (HUNTINGTON BANK)	244,522.39	6,241.07	0.00	250,763.46
001.204	HUNTINGTON LIQUIDITY PORTAL	120,500.42	688.67	0.00	121,189.09
001.300	FRANKENMUTH CREDIT UNION ACCOUNTS	213,135.20	1,063.62	0.00	214,198.82
001.306	DORT FEDERAL CREDIT UNION ACCOUNTS	212,730.58	1,143.41	0.00	213,873.99
	OMS/DDA REVLG LOAN FUND	790,888.59	9,136.77	0.00	800,025.36
Fund 243	BRA / OBRA #12 WOODWARD LOFT				
001.200	POOLED CASH (HUNTINGTON BANK)	(47.35)	0.00	0.00	(47.35)
001.201	MI CLASS ACCOUNT	1,946.12	8.41	0.00	1,954.53
	BRA / OBRA #12 WOODWARD LOFT	1,898.77	8.41	0.00	1,907.18
Fund 248	DOWNTOWN DEVELOPMENT AUTHORITY				
001.200	POOLED CASH (HUNTINGTON BANK)	20,465.92	27,126.68	12,521.00	35,071.60
001.201	MI CLASS ACCOUNT	27,518.56	118.25	0.00	27,636.81
001.203	MAIN STREET OWOSSO / DDA CHECKING	13,947.61	385.44	0.00	14,333.05
001.204	HUNTINGTON LIQUIDITY PORTAL	86,662.25	495.23	0.00	87,157.48
	DOWNTOWN DEVELOPMENT AUTHORITY	148,594.34	28,125.60	12,521.00	164,198.94
Fund 249	BUILDING INSPECTION FUND				
001.200	POOLED CASH (HUNTINGTON BANK)	131,298.84	28,724.20	18,970.24	141,052.80
001.204	HUNTINGTON LIQUIDITY PORTAL	163,712.95	935.49	0.00	164,648.44
004.000	PETTY CASH	200.00	0.00	0.00	200.00

FROM 09/01/2024 TO 09/30/2024

FUND: ALL FUNDS

CASH AND INVESTMENT ACCOUNTS

Fund Account	Description	Beginning Balance 09/01/2024	Total Debits	Total Credits	Ending Balance 09/30/2024
	BUILDING INSPECTION FUND	295,211.79	29,659.69	18,970.24	305,901.24
Fund 254	HOUSING & REDEVELOPMENT				
001.200	POOLED CASH (HUNTINGTON BANK)	(19,256.27)	64,635.19	417.00	44,961.92
001.204	HUNTINGTON LIQUIDITY PORTAL	40,673.87	232.55	0.00	40,906.42
	HOUSING & REDEVELOPMENT	21,417.60	64,867.74	417.00	85,868.34
Fund 259	OBRA-DIST#15 -ARMORY BUILDING				
001.200	POOLED CASH (HUNTINGTON BANK)	4,508.45	0.00	0.00	4,508.45
Fund 272	OBRA FUND-DISTRICT #17 CARGILL (PREV #8)				
001.200	POOLED CASH (HUNTINGTON BANK)	40,626.08	0.00	0.00	40,626.08
Fund 273	OBRA #9 ROBBINS LOFT				
001.200	POOLED CASH (HUNTINGTON BANK)	6,657.64	0.00	0.00	6,657.64
001.201	MI CLASS ACCOUNT	51,245.78	220.27	0.00	51,466.05
	OBRA #9 ROBBINS LOFT	57,903.42	220.27	0.00	58,123.69
Fund 276	OBRA FUND DISTRICT #16 - QDOBA				
001.200	POOLED CASH (HUNTINGTON BANK)	4,094.35	0.00	0.00	4,094.35
Fund 277	OBRA FUND DISTRICT #20 - J&H OIL				
001.200	POOLED CASH (HUNTINGTON BANK)	2,972.77	0.00	0.00	2,972.77
Fund 283	OBRA FUND-DISTRICT#3-TIAL				
001.200	POOLED CASH (HUNTINGTON BANK)	4,570.92	0.00	0.00	4,570.92
Fund 284	OPIOID SETTLEMENT FUND				
001.200	POOLED CASH (HUNTINGTON BANK)	32,897.14	2,146.25	0.00	35,043.39
001.204	HUNTINGTON LIQUIDITY PORTAL	26,631.07	152.22	0.00	26,783.29
	OPIOID SETTLEMENT FUND	59,528.21	2,298.47	0.00	61,826.68
Fund 287	ARPA - AMERICAN RESCUE PLAN ACT				
001.200	POOLED CASH (HUNTINGTON BANK)	(85,304.81)	95,000.00	16,155.38	(6,460.19)
001.306	DORT FEDERAL CREDIT UNION ACCOUNTS	421,169.44	1,753.04	95,000.00	327,922.48
	ARPA - AMERICAN RESCUE PLAN ACT	335,864.63	96,753.04	111,155.38	321,462.29
Fund 297	HISTORICAL FUND				
001.200	POOLED CASH (HUNTINGTON BANK)	(22,460.84)	7,936.16	3,776.07	(18,300.75)
001.202	HC CHECKING ACCOUNT	10,228.44	3,004.60	76.76	13,156.28
001.204	HUNTINGTON LIQUIDITY PORTAL	55,050.34	314.47	0.00	55,364.81
004.000	PETTY CASH	100.00	0.00	0.00	100.00
	HISTORICAL FUND	42,917.94	11,255.23	3,852.83	50,320.34
Fund 301	GENERAL DEBT SERVICE (VOTED BONDS)				
001.200	POOLED CASH (HUNTINGTON BANK)	220,498.53	462,631.10	0.00	683,129.63
Fund 588	TRANSPORTATION FUND				
001.200	POOLED CASH (HUNTINGTON BANK)	21,263.46	71,205.41	105,073.83	(12,604.96)
001.201	MI CLASS ACCOUNT	1,818.69	7.83	0.00	1,826.52
	TRANSPORTATION FUND	23,082.15	71,213.24	105,073.83	(10,778.44)
Fund 590	SEWER FUND				
001.200	POOLED CASH (HUNTINGTON BANK)	674,214.48	62,342.66	321,512.38	415,044.76
001.201	MI CLASS ACCOUNT	421,836.12	1,813.74	0.00	423,649.86
001.204	HUNTINGTON LIQUIDITY PORTAL	659,700.26	3,769.45	0.00	663,469.71
001.300	FRANKENMUTH CREDIT UNION	265,604.34	1,325.63	0.00	266,929.97

FROM 09/01/2024 TO 09/30/2024

FUND: ALL FUNDS

CASH AND INVESTMENT ACCOUNTS

Fund Account	Description	Beginning Balance 09/01/2024	Total Debits	Total Credits	Ending Balance 09/30/2024
001.306	DORT FEDERAL CREDIT UNION ACCOUNTS	537,603.86	2,889.46	0.00	540,493.32
004.000	PETTY CASH	200.00	0.00	0.00	200.00
	SEWER FUND	<u>2,559,159.06</u>	<u>72,140.94</u>	<u>321,512.38</u>	<u>2,309,787.62</u>
Fund 591	WATER FUND				
001.200	POOLED CASH (HUNTINGTON BANK)	787,546.77	525,100.36	768,633.28	544,013.85
001.201	MI CLASS ACCOUNT	1,626,446.85	6,992.86	0.00	1,633,439.71
001.204	HUNTINGTON LIQUIDITY PORTAL	2,642,926.20	15,100.53	0.00	2,658,026.73
	WATER FUND	<u>5,056,919.82</u>	<u>547,193.75</u>	<u>768,633.28</u>	<u>4,835,480.29</u>
Fund 599	WASTEWATER FUND				
001.200	POOLED CASH (HUNTINGTON BANK)	88,253.22	1,456,613.49	1,097,074.31	447,792.40
001.201	MI CLASS ACCOUNT	395,499.29	1,700.46	0.00	397,199.75
001.204	HUNTINGTON LIQUIDITY PORTAL	1,063,201.16	6,074.88	0.00	1,069,276.04
001.300	FRANKENMUTH CREDIT UNION ACCOUNTS	265,604.34	1,325.63	0.00	266,929.97
001.306	DORT FEDERAL CREDIT UNION ACCOUNTS	324,871.45	1,746.05	0.00	326,617.50
	WASTEWATER FUND	<u>2,137,429.46</u>	<u>1,467,460.51</u>	<u>1,097,074.31</u>	<u>2,507,815.66</u>
Fund 661	FLEET MAINTENANCE FUND				
001.200	POOLED CASH (HUNTINGTON BANK)	(13,424.96)	82,418.53	45,058.53	23,935.04
001.201	MI CLASS ACCOUNT	666,252.06	2,864.47	0.00	669,116.53
001.204	HUNTINGTON LIQUIDITY PORTAL	536,214.40	3,062.83	0.00	539,277.23
001.205	THE STATE BANK	1,063,520.42	3,852.90	0.00	1,067,373.32
001.300	FRANKENMUTH CREDIT UNION ACCOUNTS	542,272.95	2,706.23	0.00	544,979.18
	FLEET MAINTENANCE FUND	<u>2,794,834.87</u>	<u>94,904.96</u>	<u>45,058.53</u>	<u>2,844,681.30</u>
Fund 703	CURRENT TAX COLLECTION FUND				
001.200	POOLED CASH (HUNTINGTON BANK)	2,913,996.40	1,121,964.78	7,522,925.44	(3,486,964.26)
001.204	HUNTINGTON LIQUIDITY PORTAL	2,610,000.00	1,500,000.00	0.00	4,110,000.00
	CURRENT TAX COLLECTION FUND	<u>5,523,996.40</u>	<u>2,621,964.78</u>	<u>7,522,925.44</u>	<u>623,035.74</u>
Fund 956	GASB 34 LONG TERM DEBT				
005.200	MMRMA CASH - RESTRICTED	225,494.57	0.00	0.00	225,494.57
	TOTAL - ALL FUNDS	<u>33,151,344.50</u>	<u>9,190,483.46</u>	<u>11,301,375.02</u>	<u>31,040,452.94</u>

October 28, 2024

Nathan Henne, City Manager  
Tanya Buckelew, Planning & Building Director

RE Planning Commission Resignation

Nate & Tanya,

Please accept my resignation from the City of Owosso Planning Commission effective November 1, 2024. My professional life has become just too busy for me to commit the time necessary to be an engaged and responsible commission member.

I have enjoyed serving the citizens of Owosso via the Commission and wish you well.

Sincerely,

A handwritten signature in blue ink, appearing to read 'AM', with a stylized flourish at the end.

Allan Martin  
615 N Park St  
Owosso MI 48867



**OWOSSO HISTORICAL COMMISSION**

THE CURWOOD COLLECTION

**Regular Meeting of the Owosso Historical Commission**

**Minutes of October 15, 2024 – 6:00 P.M. at Owosso City Hall**

PRESIDING OFFICER: Chairman Mark Erickson  
MEMBERS PRESENT: Commissioners Elaine Greenway, Susan Osika, and Bill Moull  
MEMBERS ABSENT: Vice Chair Debra Adams, Commissioners Lance Little and Robert Hooper

CHAIRMAN ERICKSON CALLED THE MEETING TO ORDER AT 6:00 P.M.

**APPROVE MINUTES – SEPTEMBER 9, 2024**

Motion by Commissioner Greenway to approve the minutes as presented, supported by Commissioner Moull.

Approved by voice vote

**APPROVE AGENDA – OCTOBER 15, 2024**

Motion by Commissioner Moull to approve the agenda as presented, supported by Commissioner Greenway.

Approved by voice vote

**ITEMS OF BUSINESS**

Chair/Vice Chair Appointments: Motion by Commissioner Moull to table this item until November due to several board members being absent, supported by Commissioner Osika. Approved by voice vote.

Home Tour Finance Recap: Amy Fuller reviewed the home tour finances. Commissioner Osika said she had spoken with the committee members and they would like to contribute \$500 of the proceeds to the Castle Christmas party.

Inventory Work: Amy Fuller shared that Denice Grace has completed cataloging the Gould House items located at City Hall.

Amos Gould Portrait: Amy Fuller reported that Commissioner Little had suggested hanging the Amos Gould portrait at the Owosso Library and that Denice Grace had spoken with the library and they would be happy to have it on display. Motion by Commissioner Osika to loan the Owosso Library the Amos Gould portrait, supported by Commissioner Moull. Passed by voice vote.

Christmas at the Castle:

Party: The Castle holiday party will be December 12, 2024 from 5:30-8:30. Denice Grace will create a Facebook event and a flyer.

Decorating: Castle decorating will take place on November 18, 2024 at 2:00 p.m.

**FINANCIAL REPORTS:**

Amy Fuller reviewed the current budget and worked with the Commission on a draft budget amendment. During this conversation Commissioners discussed priorities for the current year. Motion by Commissioner Osika to authorize staff to spend \$500 on flyers for Michigan Welcome Centers, supported by Moull. Passed by voice vote.

Denice Grace reported on September numbers for Curwood Castle

**PUBLIC COMMENT PERIOD:** None

**COMMISSIONER COMMENTS**

Commissioner Osika shared that this would be her last meeting as the City Council Representative.

Commissioner Erickson reflected on the work the Commission has done over the last year.

**NEXT MEETING:** Tuesday, November 12, 2024 ay 6:00 p.m.

**ADJOURNMENT**

Commissioner Moull moved to adjourn the meeting. Commissioner Osika supported. The voice vote was unanimous to adjourn the meeting at 7:08 P.M.

Respectfully submitted by:

Amy Fuller, Assistant City Manager



**PARKS AND RECREATION COMMISSION  
REGULAR MEETING**

Draft Minutes of Wednesday, October 23, 2024  
7:00 p.m. at City Hall

**CALL TO ORDER:** Vice-Chair Selbig called the meeting to order at 7:03 p.m.

**PLEDGE OF ALLEGIANCE:** Was recited

**ROLL CALL:** Was taken by Amy Fuller

***MEMBERS PRESENT:*** Vice-Chair Selbig, Commissioners Lienau, Mahoney, and Smith.

***MEMBERS ABSENT:*** Chairman Workman, Commissioners Rodman, and Maginity.

**APPROVAL OF AGENDA:** Commissioner Mahoney made a motion to approve the agenda for October 23, 2024. Motion supported by Commissioner Smith. Ayes all, motion carried.

**APPROVAL OF MINUTES:** Commissioner Smith made a motion to approve the minutes for September 25, 2024, without changes. Motion supported by Commissioner Mahoney. Ayes all, motion carried.

**PUBLIC COMMENTS:**

Sid Fullwood, owner of Sandlot Sports Zone introduced himself to the commission. He stated that he had rented Bennett Fields for softball tournaments and wanted to apologize for making late payments and hoped the commission would consider letting him rent the fields next year.

Rick Dibeau stated he was present to support Sandlot Sports Zone.

**OLD BUSINESS REPORT:**

Amy Fuller reported that the Great Start Shiawassee Signs had been installed at the playgrounds. She also reported that the grant for sidewalks at Hugh Parker Fields had not been awarded to the city of Owosso but that they would continue with the smaller sidewalk plan this spring or summer. She provided an update on the student seat on the board and stated that she expects draft plans for the CIS trail expansion in December.

**ITEM OF BUSINESS:**

**Grand Avenue Park:** Commissioners discussed plans for Grand Avenue Park. It was decided signage should be installed on Division St. and pedestrian access on Division should be maintained. Motion made by Commissioner Smith to approve the GameTime quote for playground equipment. Support by Commissioner Mahoney. Ayes, all.

**Next Meeting:** December 4, 2024, at 7:00 PM at City Hall

**PUBLIC/COMMISSIONERS COMMENTS:**

Sid Fullwood shared the importance of low-cost activities for the youth to do in the parks.

**ADJOURNMENT:** Commissioner Smith made a motion to adjourn at 8:05 p.m. motion supported by Commissioner Mahoney. Ayes all, motion carried.

Respectfully submitted by:  
Amy Fuller, Assistant City Manager

**MINUTES**  
**REGULAR MEETING OF THE OWOSSO PLANNING COMMISSION**  
**Monday, October 28, 2024 – 6:30 P.M.**

**CALL TO ORDER:** Vice-Chair Livingston called the meeting to order at 6:30 p.m.

**PLEDGE OF ALLEGIANCE:** Recited

**ROLL CALL:** Tanya Buckelew

**MEMBERS PRESENT:** Secretary Fear, Commissioner Law, Vice-Chair Livingston, Commissioners Martin, Owens, Robertson, Schlaack and Taylor

**MEMBERS ABSENT:** None

**OTHERS PRESENT:** Tanya Buckelew, Planning & Building Director; Hannah Smith, CIB Planning

**APPROVAL OF AGENDA:**

**MOTION BY COMMISSIONER MARTIN, SUPPORTED BY COMMISSIONER ROBERTSON TO APPROVE THE AGENDA FOR October 28, 2024.**

**YEAS ALL. MOTION CARRIED.**

**APPROVAL OF MINUTES:**

**MOTION BY COMMISSIONER SCHLAACK SUPPORTED BY COMMISSIONER MARTIN TO APPROVE THE MINUTES FOR THE April 22, 2024 MEETING.**

**YEAS ALL. MOTION CARRIED.**

**ELECTION OF OFFICERS:**

**MOTION BY SECRETARY FEAR SUPPORTED BY COMMISSIONER MARTIN TO ELECT FRANK LIVINGSTON AT CHAIRMAN, LINDA ROBERTSON AS VICE-CHAIR AND JANA FEAR AS SECRETARY.**

**YEAS ALL. MOTION CARRIED.**

**SITE PLAN REVIEW:**

**1. SITE PLAN REVIEW FOR 900 ADA AND 901 N SHIAWASSEE**

The Architect for the project, Jed Dingens, stated this is for 2 quad plexes on the 2 separate lots. Four units at approximately 900 square feet each and four units at approximately 1,300 square feet. Easements are required and will be registered with the County, for the shared access to the parking lots and drainage system. MDOT has approved the plan. Mr. Dingens presented the exterior plan and color scheme.

Hannah Smith, CIB Planning, outlined the review from the City Planner Justin Sprague, noting the recommendation is to approve the site plan with conditions that further administrative review is required before permits would be issued.

Building design and materials were presented at the meeting and are consistent with the ordinance.

Mechanical units are proposed to be screened by white vinyl fencing.

**MOTION BY COMMISSIONER SCHLAACK SUPPORTED BY SECRETARY FEAR TO APPROVE THE SITE PLAN REVIEW FOR 900 ADA STREET AND 901 N SHIAWASSEE STREET CONDITIONED UPON THE FOLLOWING:**

1. **Submission of a revised site plan that satisfactorily addresses the items for administrative review and approval**
2. **That building materials are provided to determine compliance with the ordinance**
3. **That the applicant show on the plan the location and method of screening for any and all proposed exterior mechanical equipment associated with the site development and operation**
4. **That the landscaping plan be revised if additional landscaping will be utilized as a method of screening any proposed mechanical equipment**
5. **That the access and utility maintenance easement must be approved by the City as a condition of final approval**
6. **That the proposed screening wall materials are provided and approved by the Planning Commission and**
7. **Review and approval by the appropriate city departments, consultants and agencies (MDOT) prior to issuance of a building permit**

**YEAS: SECRETARY FEAR, COMMISSIONERS LAW, MARTIN, OWENS,  
SCHLAACK, TAYLOR**

**NAYS: VICE-CHAIR ROBERTSON, CHAIRMAN LIVINGSTON**

**RCV 6-2  
MOTION CARRIED**

**COMMISSIONER/CITIZEN COMMENTS:**

**ADJOURNMENT:**

**MOTION BY VICE-CHAIR ROBERTSON SUPPORTED BY SECRETARY FEAR TO ADJOURN AT 7:20 PM UNTIL THE NEXT MEETING ON NOVEMBER 25, 2024.**

**YEAS ALL, MOTION CARRIED**

---

**Janae Fear, Secretary**